

Jonesport Quadrangle, Maine

Compiled by
Craig D. Neil
Preliminary aquifer boundaries mapped by:
Daniel B. Lockie

Digital cartography by:
Michael E. Foley

Robert G. Marvinney
State Geologist

Cartographic design and editing by:
Robert D. Tucker

Funding for the preparation of this map was provided in part by the
Maine Department of Environmental Protection.



Maine Geological Survey

Address: 22 State House Station, Augusta, Maine 04333
Telephone: 207-287-2801 E-mail: mgs@maine.gov
Home page: http://www.maine.gov/doc/nrimc/nrimc.htm

Open-File No. 00-197
2000

Significant Sand and Gravel Aquifers

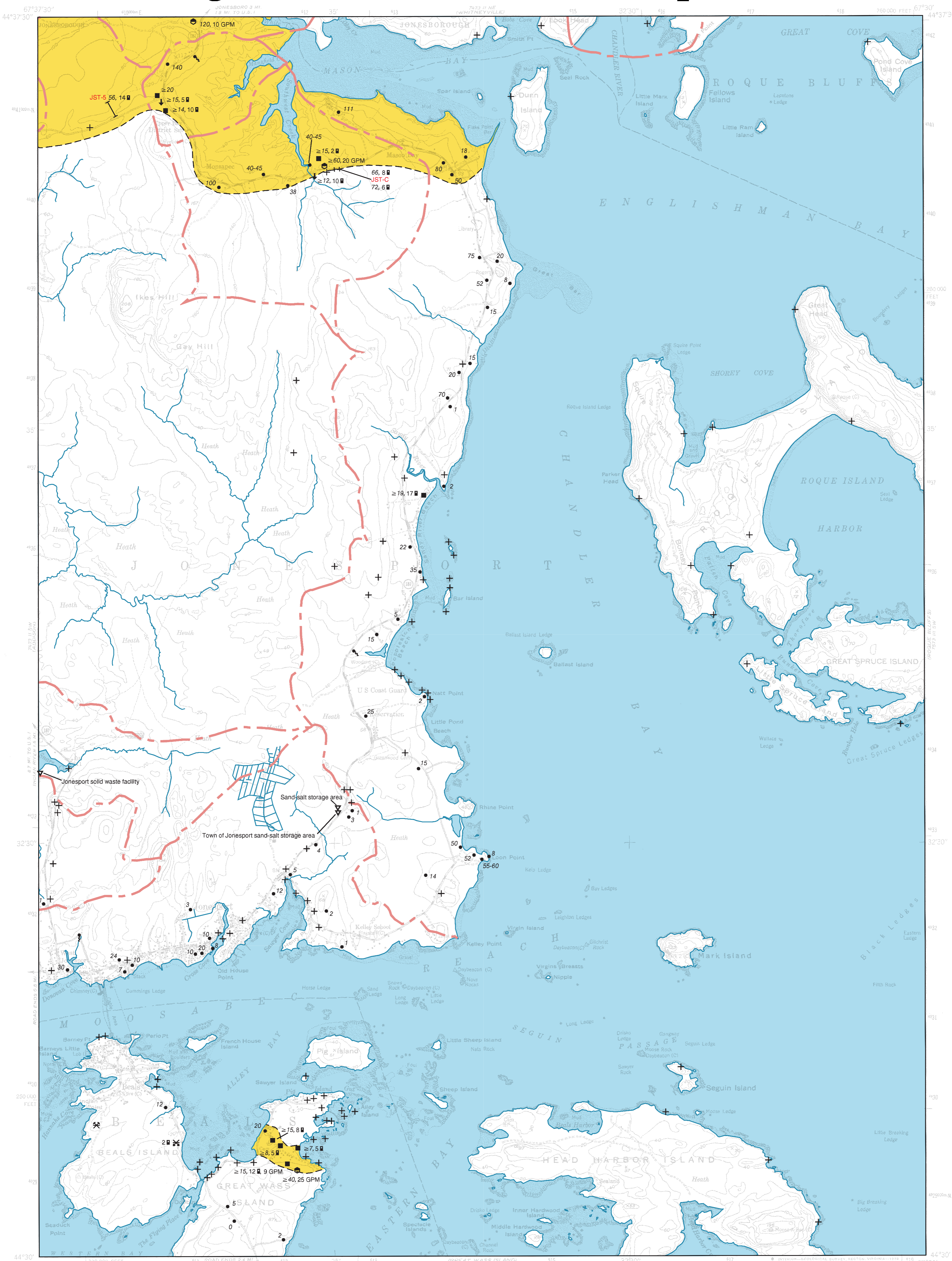

Aquifer boundaries modified from: Weddle, T. K., Neil, C. D., and Lanctot, E. M. (compilers), 1988, Significant Sand and Gravel Aquifers Map 25: Maine Geological Survey, Open-File Map 88-7c, scale 1:50,000.

Well inventory data from U. S. Geological Survey Basic-Data Reports with additional data collected by Maine Geological Survey field assistants during the 1985 field season.

Drainage basin boundaries compiled by U.S. Geological Survey, Water Resources Division, Augusta, Maine, with funding from the Maine Low-Level Radioactive Waste Authority.

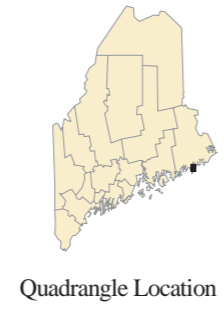

Quadrangle Location

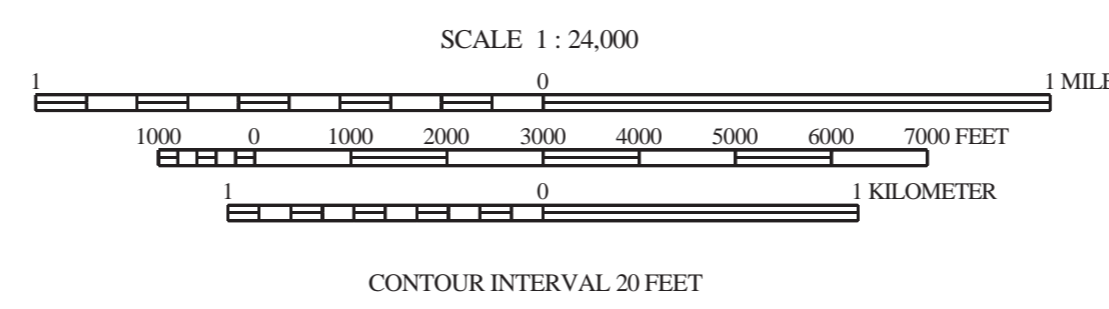

Topographic base from U.S. Geological Survey Jonesport quadrangle, scale 1:24,000 using standard U.S. Geological Survey topographic map symbols.
The use of industry, firm, or local government names on this map is for location purposes only and does not implicate responsibility for any present or potential effects on the natural resources.

SIGNIFICANT SAND AND GRAVEL AQUIFERS (yields greater than 10 gallons per minute)

- Approximate boundary of surficial deposits with significant saturated thickness where potential ground-water yield is moderate to excellent.
- Surficial deposits with good to excellent potential ground-water yield; yields generally greater than 50 gallons per minute to a properly constructed well. Deposits consist primarily of glacial sand and gravel, but can include areas of sandy till and alluvium; yield zones are based on subsurface data where available, and may vary from mapped extent in areas where data are unavailable.
- Surficial deposits with moderate to good potential ground-water yield; yields generally greater than 10 gallons per minute to a properly constructed well. Deposits consist primarily of glacial sand and gravel, but can include areas of sandy till and alluvium; yields may exceed 50 gallons per minute in deposits hydraulically connected with surface-water bodies, or in extensive deposits where subsurface data are available.

SURFICIAL DEPOSITS WITH LESS FAVORABLE AQUIFER CHARACTERISTICS (yields less than 10 gallons per minute)

- Areas with moderate to low or no potential ground-water yield (includes areas underlain by till, marine deposits, eolian deposits, alluvium, swamps, thin glacial sand and gravel deposits, or bedrock); yields in surficial deposits generally less than 10 gallons per minute to a properly constructed well.

SEISMIC-LINE INFORMATION

- Profiles for 12-channel seismic lines are shown in Figure 7 of Open-File Report 88-7a (Weddle and others, 1988). Length of seismic lines as shown on the map is to scale.
- 53 Depth to bedrock, in feet below land surface.
 - ≥53 Depth to bedrock exceeds depth shown (based on calculations).
 - 12 Depth to water level, in feet below land surface.
 - MAP-7 137, 23 Twelve-channel seismic line, with depth to bedrock and depth to water shown at the midpoint of the line, in feet below land surface.
 - MAP-E 69, 12 Single-channel seismic line, with depth to bedrock and depth to water shown at each end of the line, in feet below land surface.
 - 72, 12 Unless otherwise indicated, data shown above the line-identifier box refers to the northern end of the seismic line.

The 3-letter identifier for a line is an abbreviation for the topographic map. If the 3-letter identifier for the line is followed by a number (ex: MAP - 7, MAP - 4), the line is a 12-channel line. If the identifier is followed by a letter (ex: MAP - E, MAP - P), the line is a single-channel line. Single-channel seismic interpretations by C. D. Neil. Twelve-channel seismic interpretations by J. D. Adamik and C. D. Neil.

GEOLOGIC AND WELL INFORMATION

- 50 Depth to bedrock, in feet below land surface
- ≥13 Penetration depth of boring; ≥ symbol refers to minimum depth to bedrock based on boring depth or refusal
- 6 Depth to water level in feet below land surface (observed in well, spring, test boring, pit, or seismic line)
- X Gravel pit (overburden thickness in feet, e.g. 5-12')
- Q Quarry
- 4 GPM Yield (flow) of well or spring in gallons per minute (GPM)
- Spring, with general direction of flow
- Drilled overburden well
- Dug well
- Observation well (project well if labeled, nonproject well if unlabeled)
- Test boring (project boring if labeled, nonproject boring if unlabeled)
- Driven point
- Test pit
- Drilled bedrock well
- Potential point source of ground-water contamination
- Bedrock outcrop
- Surface-water drainage-basin boundary; surface-water divides generally correspond to ground-water divides. Horizontal direction of ground-water flow generally is away from divides and toward surface-water bodies.

OTHER SOURCES OF INFORMATION

1. Weddle, T. K., Tolman, A. L., Williams, J. S., Adamik, J. T., Neil, C. D., and Steiger, K. I., 1988, Hydrogeology and water quality of significant sand and gravel aquifers in parts of Hancock, Penobscot, and Washington Counties, Maine: Maine Geological Survey, Open-File Report 88-7a, 94 p.
2. Locke, D. B., 2000, Surficial materials of the Jonesport quadrangle, Maine: Maine Geological Survey Open-File Map 00-172.
3. Borns, H. W., 1975, Reconnaissance surficial geology of the Columbia Falls 15' quadrangle, Maine: Maine Geological Survey, Open-File Map 75-1.
4. Thompson, W. B., 1977, Reconnaissance surficial geology of the Jonesport 7.5' quadrangle, Maine: Maine Geological Survey, Open-File Map 77-31.
5. Caswell, W. B., 1987, Ground water handbook for the state of Maine, Second Edition: Maine Geological Survey, Bulletin 39, 135 p.
6. Thompson, W. B., 1979, Surficial geology handbook for coastal Maine: Maine Geological Survey, 68 p. (out of print)
7. Thompson, W. B., and Borns, H. W., Jr., 1985, Surficial geologic map of Maine: Maine Geological Survey, scale 1:500,000.