

# New Portland Quadrangle, Maine

Compiled by  
**Elizabeth B. Lewis, Daniel B. Locke, and Craig D. Neil**  
 Preliminary aquifer boundaries mapped by:  
**Thomas K. Weddle**

Digital cartography by:  
**Michael E. Foley**

**Robert G. Marvinney**  
 State Geologist

Cartographic design and editing by:  
**Robert D. Tucker**

Funding for the preparation of this map was provided in part by the  
 U. S. Geological Survey.



## Maine Geological Survey

Address: 22 State House Station, Augusta, Maine 04333  
 Telephone: 207-287-2801 E-mail: mgs@maine.gov  
 Home page: http://www.maine.gov/doc/nrmc/nrmc.htm

## Open-File No. 09-53 2009

This map supersedes  
 Open-File Map 01-174.

# Significant Sand and Gravel Aquifers

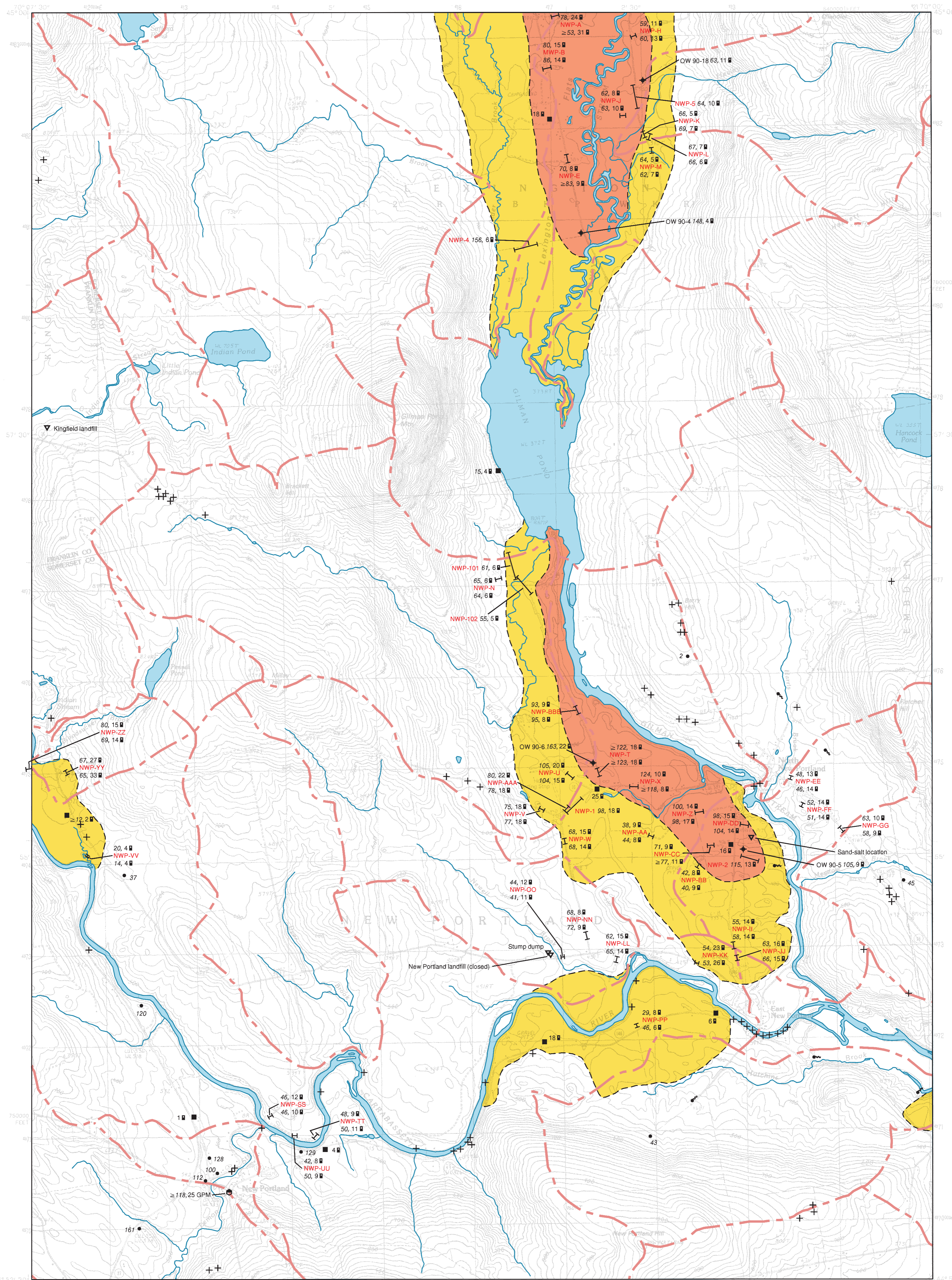

Aquifer boundaries modified from: Tolman, A. L., and Lanctot, E. M., 1981, Sand and Gravel Aquifer Map 37, Maine Geological Survey, Open-File Map 81-69, scale 1:50,000.

Well inventory data collected by Maine Geological Survey field assistants during the 1990 and 2008 field seasons.

Drainage basin boundaries compiled by U.S. Geological Survey, Water Resources Division, Augusta, Maine, with funding from the Maine Low-Level Radioactive Waste Authority.



Quadrangle Location

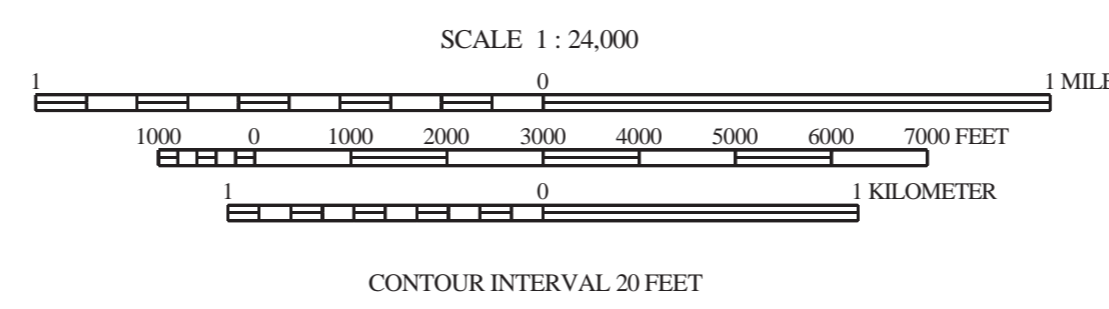

Topographic base from U.S. Geological Survey New Portland quadrangle, scale 1:24,000 using standard U.S. Geological Survey topographic map symbols.  
 The use of industry, firm, or local government names on this map is for location purposes only and does not implicate responsibility for any present or potential effects on the natural resources.

### SIGNIFICANT SAND AND GRAVEL AQUIFERS (yields greater than 10 gallons per minute)

- Approximate boundary of surficial deposits with significant saturated thickness where potential ground-water yield is moderate to excellent.
- Orange box: Surficial deposits with good to excellent potential ground-water yield; yields generally greater than 50 gallons per minute to a properly constructed well. Deposits consist primarily of glacial sand and gravel, but can include areas of sandy till and alluvium; yield zones are based on subsurface data where available, and may vary from mapped extent in areas where data are unavailable.
- Yellow box: Surficial deposits with moderate to good potential ground-water yield; yields generally greater than 10 gallons per minute to a properly constructed well. Deposits consist primarily of glacial sand and gravel, but can include areas of sandy till and alluvium; yields may exceed 50 gallons per minute in deposits hydraulically connected with surface-water bodies, or in extensive deposits where subsurface data are available.

### SURFICIAL DEPOSITS WITH LESS FAVORABLE AQUIFER CHARACTERISTICS (yields less than 10 gallons per minute)

- White box: Areas with moderate to low or no potential ground-water yield (includes areas underlain by till, marine deposits, eolian deposits, alluvium, swamps, thin glacial sand and gravel deposits, or bedrock); yields in surficial deposits generally less than 10 gallons per minute to a properly constructed well.

### SEISMIC-LINE INFORMATION

Profiles for 12-channel seismic lines are shown in Appendix 2 of Open-File Report 95-37 (Foster and others, 1995). Length of 12-channel seismic lines as shown on the map is to scale. All single-channel lines ranged from 80 to 300 feet long and are not shown to scale.

- 53 Depth to bedrock, in feet below land surface.
- ≥53 Depth to bedrock exceeds depth shown (based on calculations).
- 12 Depth to water level, in feet below land surface.
- MAP-7 137, 23 Twelve-channel seismic line, with depth to bedrock and depth to water shown at the midpoint of the line, in feet below land surface.
- 69, 12 Single-channel seismic line, with depth to bedrock and depth to water shown at each end of the line, in feet below land surface.
- MAP-E 72, 12 Unless otherwise indicated, data shown above the line-identifier box refers to the northern end of the seismic line.

The 3-letter identifier for a line is an abbreviation for the topographic quadrangle. If the 3-letter identifier for the line is followed by a number (ex: MAP - 7, MAP - 4), the line is a 12-channel line. If the identifier is followed by a letter (ex: MAP - E, MAP - P), the line is a single-channel line. Single-channel seismic interpretations by L. E. Foster. Twelve-channel seismic interpretations by C. D. Neil and W. J. Nichols, Jr.

### GEOLOGIC AND WELL INFORMATION

- 50 Depth to bedrock, in feet below land surface
  - ≥13 Penetration depth of boring; ≥ symbol refers to minimum depth to bedrock based on boring depth or refusal
  - 6 Depth to water level in feet below land surface (observed in well, spring, test boring, pit, or seismic line)
  - X Gravel pit (overburden thickness noted in feet, e.g. 5-12')
  - Q Quarry
  - 4 GPM Yield (flow) of well or spring in gallons per minute (GPM)
  - Spring, with general direction of flow
  - Drilled overburden well
  - Dug well
  - ◆ Observation well (project well if labeled; nonproject well if unlabeled)
  - ◇ Test boring (project boring if labeled; nonproject boring if unlabeled)
  - ↓ Driven point
  - ⊙ Test pit
  - Drilled bedrock well
  - ▼ Potential point source of ground-water contamination
  - ⊕ Bedrock outcrop
- Surface-water drainage-basin boundary; surface-water divides generally correspond to ground-water divides. Horizontal direction of ground-water flow generally is away from divides and toward surface-water bodies.

### OTHER SOURCES OF INFORMATION

1. Foster, L. E., Lewis, E. B., Nichols, W. J., Jr., Neil, C. D., and Weddle, T. K., 1995, Hydrogeology and water quality of significant sand and gravel aquifers in parts of Franklin, Oxford, and Somerset Counties, Maine: Maine Geological Survey, Open-File Report 95-37, 82 p.
2. Hildreth, C. T., and Weddle, T. K., 2007, Surficial materials of the New Portland quadrangle, Maine: Maine Geological Survey Open-File Map 07-72.
3. Hildreth, C. T., 2009, Surficial geology of the New Portland quadrangle, Maine: Maine Geological Survey, Open-File Map 09-47.
4. Caswell, W. B., 1987, Ground water handbook for the state of Maine, Second Edition: Maine Geological Survey, Bulletin 39, 135 p.
5. Thompson, W. B., 1979, Surficial geology handbook for coastal Maine: Maine Geological Survey, 68 p. (out of print)
6. Thompson, W. B., and Borns, H. W., Jr., 1985, Surficial geologic map of Maine: Maine Geological Survey, scale 1:500,000.