

MODIFICATION

State of Maine**Master Agreement****Effective Date:** 05/07/15**Expiration Date:** 05/06/18**Master Agreement Description:** Above Ground Single & Dual Compartment Fuel Tanks**Buyer Information**

Terry Demerchant 207-624-7334 ext. TERRY.L.DEMERCHANT@MAINE.GOV

Issuer Information

Jessica Norton 207-624-8226 ext. Jessica.h.norton@MAINE.GOV

Requestor Information

Jessica Norton 207-287-5506 ext. Jessica.h.norton@MAINE.GOV

Authorized Departments

17D MOTOR TRANSPORT

Vendor Information**Vendor Line #:** 1**Vendor ID**

VC1000044964

Vendor Name

JOHN W KENNEDY CO INC

Alias/DBA**Vendor Address Information**

PO BOX 14217

E PROVIDENCE, RI 02914

US

Vendor Contact Information

DAVID L BLANCHETTE

888-667-0667 ext.

dlb@jwkemail.com

Commodity Information

Vendor Line #: 1

Vendor Name: JOHN W KENNEDY CO INC

Commodity Line #: 1

Commodity Code: 83069

Commodity Description: Above Ground Single & Dual Compartment Fuel Tanks

Commodity Specifications:

Commodity Extended Description: Above Ground Single & Dual Compartment Fuel Tanks As per the specifications attached and made part of this MA.

Quantity 0.00000	UOM	Unit Price \$0.00
Delivery Days 70	Free on Board	
Contract Amount \$0.00	Service Start Date	Service End Date
Catalog Name TANKS	Discount 0.0000 %	
	Discount Start Date 05/07/15	Discount End Date 05/06/18

Terms and Conditions

Agreement Terms and Conditions

T&C #: 165

T&C Name: Payment Terms

T&C Details: Net 30

Division of Purchases
Burton M Cross Bldg.
9 State House Station
Augusta, ME 04333-0009
Tel. (207) 624-7334
Fax.# (207) 624-5086

Contract Number
MA 150507*232

EXTENSION OF ANNUAL CONTRACT

Commodity Item: Above Ground Single & Dual Compartment Fuel Tanks

Contractor: John W Kennedy Co Inc

Contract Period Extended To: 5/6/18

Current Pricing: See attached spreadsheet

New Lower Pricing: Adjust attached spreadsheet and e-mail back to me with this form

Extension Clause: The State reserves the right to extend this contract for a period of one year, with the consent of the contractor.

Agreement to Extend Contract:

In accordance with the above referenced Extension Clause, the undersigned agrees to continue in effect said Contract No # MA 050507*232 until May 6, 2018 with all terms, conditions remaining as shown in the original contract.

Copy of which is acknowledged on this date.

Contractor: JOHN W. KENNEDY CO

By: DAVID L. BLANCHETTE OPERATIONS MANAGER

E-mail Address: DLB@JWKEMAIL.COM

Date: 6-9-17

Dollar value the State has spent on this contract from 5/7/16 to present: \$



MANUFACTURER NAME	MANUFACTURER PART NUMBER	COMMODITY CODE	ITEM DESCRIPTION	EXTENDED DESCRIPTION	UNIT OF MEASURE	LIST PRICE	DELIVERY DAYS	PRODUCT/C CATEGORY	MODEL
edy		83069	4000 Gal Single Compart Tank Complete w/TLS4C Veed Root Sys	N/A	ea	\$49,684.89	70		
edy		83069	6000 Gal Single Compart Tank Complete w/TLS4C Veed Root Sys	N/A	ea	\$52,884.89	70		
edy		83069	8000 Gal Single Compart Tank Complete w/TLS4C Veed Root Sys	N/A	ea	\$55,648.22	70		
edy		83069	10000 Gal Single Compart Tank Complete w/TLS4C Veed Root Sys	N/A	ea	\$59,279.33	70		
edy		83069	12000 Gal Single Compart Tank Complete w/TLS4C Veed Root Sys	N/A	ea	\$62,782.67	70		
edy		83069	8000 Gal Dual Compart Tank Complete w/TLS4C Veed Root Sys	w/ Dual Tank	ea	\$82,632.11	70		
edy		83069	12000 Gal Dual Compart Tank Complete w/TLS4C Veed Root Sys	w/ Dual Tank	ea	\$89,766.56	70		
edy		83069	12000 Gal Dual Compart Tank Complete w/TLS4C Veed Root Sys	w/ Dual Tank	ea	\$89,766.56	70		

The John W. Kennedy Co. will hold pricing thru 5-30-18.

Thank you

James J. [Signature]
 Operations Manager

State of Maine
Department of Administrative and Financial Services
Bureau of General Services
Division of Purchases

QUOTATION SPECIFICATION FORM

RFQ # 17D 1503170000000000749

Above Ground Dual/Split Compartment Fuel Tank

MaineDOT Dual/Split Compartment AST

The purpose and intent of these specifications is to describe Dual/Split compartment double wall steel self-contained Above Ground Storage Tank (AST) with dispensers.

INSTRUCTIONS FOR COMPLETING TECHNICAL SPECIFICATION SHEET

Please complete the checklist for technical specifications set forth below. Each Bidder must indicate whether it can meet the technical specifications by inserting an "X" next to each specification. The "X" will demonstrate that the Bidder's offering meets the technical specification. If a Bidder cannot meet a technical specification, then the Bidder must give an explanation for each exception and for equipment that is not available or that will be dealer installed. All explanations must be provided in detail on separate pages along with the justification as to why the alternative equipment or deliverables will be as good as the equipment or deliverables described in the detailed specifications for desired items. A copy of the vendor specification proposal must be provided. Following these instructions is essential for proper bid evaluation. **If a Bidder fails to provide requested information or if information on a quote is found to be false or misleading, the quote will be rejected as unresponsive. The award will be made on a best value basis to the vendor that either meets or most closely meets the specifications, while taking price and delivery into consideration.**

The following abbreviations must be used by interested Bidders:

X	Meeting Specification
N/A	Not Available
DI	Dealer Installed
AE	Approved equal process

1.0 Standards

- 1.1 Acceptable Manufacturer: Modern Welding Company of Ohio, Inc or approved equivalent. The State of Maine reserves the right to evaluate alternates and determine equivalency, in accordance with 5 MRSA §1825(B), "Alternate Bids".
- 1.2 U.L. 142, Underwriters Laboratories, Inc., Steel Aboveground Tanks for Flammable and Combustible Liquids.
- 1.3 U.L. 2085, Underwriters Laboratories 2 Hour Fire Rating's Standard for Insulated Aboveground Storage Tanks for Flammable and Combustible Liquids.
- 1.4 NFPA 30, National Fire Protection Association Flammable and Combustible Code.
- 1.5 NFPA 30A, National Fire Protection Association Automotive and Marine Service Station Code.
- 1.6 Uniform Fire Code International Fire Code Institute.
- 1.7 B.O.C.A. National Fire Prevention Code.
- 1.8 NFPA 31, Standard for Installation of Oil Burning Equipment.
- 1.9 PEI/RP200- Petroleum Equipment Institute, Recommended Practices for Installation of Aboveground Storage Systems for Motor Vehicle Fueling.

2.0 Submittals

- 2.1 Shop Drawings: Contractor shall submit Three 3 ___ copies of shop drawings for each tank, location of fittings, and accessories with specific dimensions shall be shown on all drawings.
- 2.2 Drawing Approval: Contractor shall receive drawing approval prior to product fabrication.
- 2.3 Catalog Data: Contractor shall submit ___3___ current copies of manufacturer's literature.
- 2.4 Certification: Each tank shall bear the U.L. 2085 label for "Insulated Secondary Containment Aboveground Tank for Flammable Liquids."

3.0 Product Description

- 3.1 Only new material shall be used in the manufacturing process, and the manufacturer shall ensure that the material used meets all appropriate specifications and quality assurance requirements.
- 3.2 Nominal capacity of the Double Bulkhead tanks are listed below
- 3.3 Two hour fire rated, ballistics, impact and steam hose certified.
- 3.4 Minimal material thickness of the tank(s) shall be per UL-142 requirements.
- 3.5 Minimum annular space insulation thickness material to be 3" with only UL-2085 listed insulation material.
- 3.6 Internal Load: Tank shall be able to withstand an air pressure test of 3 to 5 psi.
- 3.7 Tank shall be designed to support accessory equipment such as ladders, pumps, floating suction, etc. when installed according to manufacturer's instructions and limitations.
- 3.8 Tank(s) shall be provided with suitably designed and located lifting lugs which have a 2:1 safety factor.
- 3.9 NO Catwalk installed but available at a future time.
- 3.10 Tank(s) shall be capable of storing liquids with a specific gravity up to 1.0.
- 3.11 Tank(s) is designed for operation at atmospheric pressure only. Both inner and outer tanks shall have openings of sufficient size to meet normal and emergency venting requirements stated in U.L. 142, UFC and NFPA.
- 3.12 Tank(s) shall be capable of storing gasoline and diesel fuel at ambient temperatures.
- 3.13 Tank shall be constructed with butt welded or offset joint construction. Lap welded seams will not be accepted.
- 3.14 Certification Plate: Underwriters Laboratories label "Insulated Secondary Containment Aboveground Tank for Flammable Liquids." shall be affixed to each tank.
- 3.15 Approved flexible connectors at all flanged connections.
- 3.16 All threaded fittings shall be of a material of construction consistent with the requirements of the Underwriters Laboratories. All fittings shall be protected using threaded plugs or suitable closure caps.

- 3.17 All flanged nozzles shall be of a material of construction consistent with the requirements of the Underwriters Laboratories. All nozzles shall be protected using suitable closure caps.
- 3.18 Manways shall conform to Underwriters Laboratories 142 standard with regard to construction, bolting and gaskets.
- 3.19 Design of the steel supports shall be per approved UL listing and be able to support the weight of the tank filled to capacity.
- 3.20 Two Gasboy or approved equivalent single hose, single product 18-22 GPM dispensers will be installed on one end under rainhood (Gas/Diesel).
- 3.21 Two ¾ HP FE Petro or approved equivalent submersible pumps.
- 3.22 Simplex dual product remote fill (Gas/Diesel).
- 3.23 Separate Morrison Brothers or approved equivalent overfill valves for each compartment.
- 3.24 Separate Morrison Brothers or approved equivalent clock gauges for each compartment.
- 3.25 Three 8" Morrison Brothers or approved equivalent emergency vents.
- 3.26 One 5' rainhoods.
- 3.27 One 5'x5' Dispenser Pans.
- 3.28 All welded or flanged steel pipe.
- 3.29 Proper valves and fittings for above listed equipment for a complete system.
- 3.30 Product identification and warning labels.
- 3.31 Color – off white or almond.
- 3.32 One end of tank needs to have accessibility for stick measuring

4.0 Delivery

- 4.1 Must be delivered. Deliveries locations varies from Kittery Maine to Madawaskas Maine. MDOT will be responsible for providing equipment to remove tanks for trailers.
- 4.2 Vendor must notify MaineDot two weeks prior to delivery of delivery date.

5.0 Air Tank Test

- 5.1 The primary and secondary tanks shall successfully complete an air pressure test prior to installation. While maintaining pressure of 3-5 psig on the primary tank, the annular space bounded by the primary and secondary containment tank shall be pressurized to 1 1/2 to 3 psig. The secondary tank shall then be checked for tightness. **Tested on delivery**

6.0 Tank Options: Priced Separately

On a separate document list any optional equipment and their corresponding prices not listed in these specifications.

- 6.1 Veeder-Root TLS-350 Automatic Tank Gauge system and compatible remote fuel management software required to operate offsite or approved equivalent to be installed.
- 6.2 Veeder-Root TLS4C Automatic Tank Gauge system and compatible remote fuel management software required to operate offsite or approved equivalent to be installed.
- 6.3 A Catwalk that is capable of being installed later.

7.0 Dual Compartment AST Tanks: Priced Separately

- 7.1 4000 Gal / 4000 Gal
- 7.2 6000 Gal / 6000 Gal
- 7.3 4000 Gal / 8000 Gal

8.0 Warranty

- 8.1 Terms and conditions of warranty must be provided with bid proposal.
- 8.2 Terms and conditions of warranty must be provided with bid proposal (Warranty must be clearly defined and all components covered must be clearly listed and identified).
- 8.3 Vendor shall be (100%) responsible for all repair costs to include parts, labor during the warranty period.

Appendix B

**State of Maine
DEPARTMENT OF ADMINISTRATIVE AND FINANCIAL SERVICES
DIVISION OF PURCHASES
BID COVER PAGE**

Bidder's Organization Name: <u>JOHN W. KENNEDY COMPANY</u>		
Chief Executive - Name/Title: <u>JO ANNE KENNEDY - OWNER</u>		
Tel: <u>800-451-4021</u>	Fax: <u>401-434-6630</u>	E-mail: <u>JOJOKEN411@ICLOUD.COM</u>
Headquarters Street Address: <u>990 WATERMAN AVENUE</u>		
Headquarters City/State/Zip: <u>EAST PROVIDENCE, R.I. 02914</u>		
<i>(provide information requested below if different from above)</i>		
Lead Point of Contact for Bid - Name/Title: <u>DAVID L. BLANCHETTE - OPERATION MGR.</u>		
Tel: <u>207-441-3481</u>	Fax: <u>207-942-3197</u>	E-mail: <u>DLB@JWKEMAIL.COM</u>
Street Address: <u>51 CAREY CIRCLE</u>		
City/State/Zip: <u>HAMPDEN, MAINE 04444</u>		

- This bid and the pricing structure contained herein will remain firm for a period of 180 days from the date and time of the bid opening.
- No personnel currently employed by the Department or any other State agency participated, either directly or indirectly, in any activities relating to the preparation of the Bidder's proposal.
- No attempt has been made or will be made by the Bidder to induce any other person or firm to submit or not to submit a proposal.
- The undersigned is authorized to enter into contractual obligations on behalf of the above-named organization.

Debarment, Performance, and Non-Collusion Certification

By signing this document I certify to the best of my knowledge and belief that the aforementioned organization, its principals, and any subcontractors named in this proposal:

- a. Are not presently debarred, suspended, proposed for debarment, and declared ineligible or voluntarily excluded from bidding or working on contracts issued by any governmental agency.
- b. Have not within three years of submitting the proposal for this contract been convicted of or had a civil judgment rendered against them for:
 - i. fraud or a criminal offense in connection with obtaining, attempting to obtain, or performing a federal, state or local government transaction or contract.
 - ii. violating Federal or State antitrust statutes or committing embezzlement, theft, forgery, bribery, falsification or destruction of records, making false statements, or receiving stolen property;
 - iii. are not presently indicted for or otherwise criminally or civilly charged by a governmental entity (Federal, State or Local) with commission of any of the offenses enumerated in paragraph (b) of this certification; and
 - iv. have not within a three (3) year period preceding this proposal had one or more federal, state or local government transactions terminated for cause or default.
- c. Have not entered into a prior understanding, agreement, or connection with any corporation, firm, or person submitting a response for the same materials, supplies, equipment, or services and this proposal is in all respects fair and without collusion or fraud. The above mentioned entities understand and agree that collusive bidding is a violation of state and federal law and can result in fines, prison sentences, and civil damage awards.

- **Failure to provide this certification may result in the disqualification of the Bidder's proposal, at the discretion of the Department.**

To the best of my knowledge all information provided in the enclosed proposal, both programmatic and financial, is complete and accurate at the time of submission.

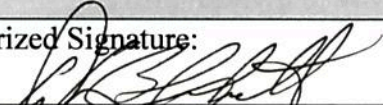
Name: <i>DAVID L. BLANCHETTE</i>	Title: <i>OPERATIONS MANAGER</i>
Authorized Signature: 	Date: <i>4-3-2015</i>

State of Maine Tank Bid Summary

Product Summary	Description	Sell Price
Veeder Root	Single Tank TLS350 Complete System	\$ 11,301.67
Veeder Root	Single Tank TLS4C Complete System	\$ 6,507.47
Veeder Root	Dual Tank TLS350 Complete System	\$ 13,383.70
Veeder Root	Dual Tank TLS4C Complete System	\$ 8,589.50
Modern Tank Catwalk	Catwalk and ladder for a 4000 gallon tank. Delivered	\$ 8,292.22
Modern Tank Catwalk	Catwalk and ladder for a 6000 gallon tank. Delivered	\$ 9,553.33
Modern Tank Catwalk	Catwalk and ladder for a 8000 gallon tank. Delivered	\$ 10,814.44
Modern Tank Catwalk	Catwalk and ladder for a 10000 gallon tank. Delivered	\$ 12,325.56
Modern Tank Catwalk	Catwalk and ladder for a 12000 gallon tank. Delivered	\$ 13,581.11
Modern Tank	4000 Gallon Single Compartment Tank Complete	\$ 43,177.42
Modern Tank	6000 Gallon Single Compartment Tank Complete	\$ 46,377.42
Modern Tank	8000 Gallon Single Compartment Tank Complete	\$ 49,140.75
Modern Tank	10000 Gallon Single Compartment Tank Complete	\$ 52,771.86
Modern Tank	12000 Gallon Single Compartment Tank Complete	\$ 56,275.20
Modern Tank	8000 Gallon Dual Compartment Tank Complete 4/4	\$ 74,042.61
Modern Tank	12000 Gallon Dual Compartment Tank Complete 6/6	\$ 81,177.06
Modern Tank	12000 Gallon Dual Compartment Tank Complete 8/4	\$ 81,177.06

John W. Kennedy Company - ME
51 Carey Circle
HAMPDEN, ME 04444
207-942-0767 Fax 207-942-3197

Quotation

QUOTE DATE	QUOTE NUMBER
04/01/15	S1461866
ORDER TO: John W. Kennedy Company - ME 51 Carey Circle HAMPDEN, ME 04444 207-942-0767 Fax 207-942-3197	PAGE NO. 1

QUOTE TO:
 State of Maine Motor Transport Svc.
 26 State House Station
 (Mdot) Attn: T. Sirois
 AUGUSTA, ME 04333

SHIP TO:
 State of Maine Motor Transport
 26 State House Station
 (Mdot) Attn: T. Sirois
 AUGUSTA, ME 04333

CUSTOMER NUMBER	CUSTOMER ORDER NUMBER	RELEASE NUMBER	SALESPERSON	
1797	TLS4C - Two Tank Sys		David Blanchette	
WRITER	SHIP VIA	TERMS	SHIP DATE	PHONE
David Blanche	PK PICKUP	Net Due 20 Days	04/01/15	207-287-2543
ORDER QTY	PART NO	DESCRIPTION	UNIT PRICE	NET AMOUNT
1ea	860199-020	860199-020 Veeder-Root TLS4C Non-Expandable Console, 6 Inputs, Ethernet, 7" Color LCD Touch Screen, RS232 Port, Maximum number of Probes is 2. ** Special Order NON-Returnable **	946.400	946.40
1ea	333577-001	333577-001 Veeder Root TLS4C Application Software. ** Special Order NON-Returnable **	1487.200	1487.20
2ea	846390-107	846390-107 Veeder Root 8' 0.1-GPH Mag Plus Probe.	1647.000	3294.00
1ea	846400-001	846400-001 Veeder Root " Diesel " Mag Plus Probe Installation Kit w/ 5' Cable and 4" Float.	238.500	238.50
1ea	886100-000	886100-000 Veeder Root 4" Phase Separation Detecting Float Kit w/ 5' Cable.	364.500	364.50
2ea	305XPA1200	305XPA1200AKEVR Morrison Brothers 4" Tank Monitor Cap and Adaptor w/ 1/2" Conduit Hole.	60.531	121.06
1ea	305XPA2400	- CARB EVR-Approved 305XPA-2400AKEVR Morrison Brothers 2" Tank Monitor Cap/Adaptor w/ - Cable Connector - 1/2" Hole	55.040	55.04

*** Continued on Next Page ***

John W. Kennedy Company - ME
51 Carey Circle
HAMPDEN, ME 04444
207-942-0767 Fax 207-942-3197

Quotation

QUOTE DATE	QUOTE NUMBER
04/01/15	S1461866
ORDER TO: John W. Kennedy Company - ME 51 Carey Circle HAMPDEN, ME 04444 207-942-0767 Fax 207-942-3197	PAGE NO. 2

QUOTE TO:
 State of Maine Motor Transport Svc.
 26 State House Station
 (Mdot) Attn: T. Sirois
 AUGUSTA, ME 04333

SHIP TO:
 State of Maine Motor Transport
 26 State House Station
 (Mdot) Attn: T. Sirois
 AUGUSTA, ME 04333

CUSTOMER NUMBER	CUSTOMER ORDER NUMBER	RELEASE NUMBER	SALESPERSON	
1797	TLS4C - Two Tank Sys		David Blanchette	
WRITER	SHIP VIA	TERMS	SHIP DATE	PHONE
David Blanche	PK PICKUP	Net Due 20 Days	04/01/15	207-287-2543

ORDER QTY	PART NO	DESCRIPTION	UNIT PRICE	NET AMOUNT
		- CARB/EVR Approved		
1ea	794390-420	794390-420 Veeder Root Steel Tank Interstitial Sensor w/ 16' Cable.	370.800	370.80
1ea	794380-208	794380-208 Veeder Root Piping Sump Sensor W/ 12' Cable.	209.700	209.70
1ea	848940-010	848940-010 Veeder Root Single Site Inform Software.	592.200	592.20
		** Special Order NON-Returnable **		
1ea	790095-001	790095-001 Veeder Root Overfill Alarm Acknowledgement Switch.	345.600	345.60
1ea	790091-001	790091-001 Veeder Root Audible / Visual Overfill Alarm.	544.500	544.50
		TAXES NOT INCLUDED		

*** This is a quotation ***

Prices are firm for 30 days and subject to
 change without notice after 30 days.

Applicable taxes extra!

Subtotal	8569.50
S&H CHGS	20.00
Amount Due	8589.50

John W. Kennedy Company - ME
51 Carey Circle
HAMPDEN, ME 04444
207-942-0767 Fax 207-942-3197

Quotation

QUOTE DATE	QUOTE NUMBER
04/01/15	S1461844
ORDER TO: John W. Kennedy Company - ME 51 Carey Circle HAMPDEN, ME 04444 207-942-0767 Fax 207-942-3197	PAGE NO. 1

QUOTE TO:
 State of Maine Motor Transport Svc.
 26 State House Station
 (Mdot) Attn: T. Sirois
 AUGUSTA, ME 04333

SHIP TO:
 State of Maine Motor Transport
 26 State House Station
 (Mdot) Attn: T. Sirois
 AUGUSTA, ME 04333

CUSTOMER NUMBER	CUSTOMER ORDER NUMBER	RELEASE NUMBER	SALESPERSON	
1797	V/R Two Tank Sys.		David Blanchette	
WRITER	SHIP VIA	TERMS	SHIP DATE	PHONE
David Blanche	PK PICKUP	Net Due 20 Days	04/01/15	207-287-2543
ORDER QTY	PART NO	DESCRIPTION	UNIT PRICE	NET AMOUNT
1ea	848290-022	848290-022 Veeder Root TLS350 Plus Console w/ Integral Printer.	3798.000	3798.00
1ea	329358-001	329358-001 Veeder Root TLS350R / TLS350 Plus 8 Input Interstitial / Liquid Sensor Interface Module.	1006.200	1006.20
1ea	329356-002	329356-002 Veeder Root TLS350R / TLS350 Plus 4 Input Probe Interface Module.	666.000	666.00
1ea	329359-001	329359-001 Veeder Root TLS350R / TLS350 Plus, 4 Relay Output Interface Module.	262.800	262.80
1ea	330020-425	330020-425 Veeder Root TLS350R / TLS350 Plus Ethernet TCP / IP Communications Interface Module. !! Will NOT Work With ModBus !!	766.800	766.80
2ea	846390-107	846390-107 Veeder Root 8' 0.1-GPH Mag Plus Probe.	1647.000	3294.00
1ea	846400-001	846400-001 Veeder Root " Diesel " Mag Plus Probe Installation Kit w/ 5' Cable and 4" Float.	238.500	238.50
1ea	886100-000	886100-000 Veeder Root 4" Phase Separation Detecting Float Kit w/ 5' Cable.	364.500	364.50
2ea	305XPA1200	305XPA1200AKEVR Morrison Brothers 4" Tank Monitor Cap and Adaptor w/ 1/2" Conduit	60.531	121.06

*** Continued on Next Page ***

John W. Kennedy Company - ME
51 Carey Circle
HAMPDEN, ME 04444
207-942-0767 Fax 207-942-3197

Quotation

QUOTE DATE	QUOTE NUMBER
04/01/15	S1461844
ORDER TO: John W. Kennedy Company - ME 51 Carey Circle HAMPDEN, ME 04444 207-942-0767 Fax 207-942-3197	PAGE NO. 2

QUOTE TO:
 State of Maine Motor Transport Svc.
 26 State House Station
 (Mdot) Attn: T. Sirois
 AUGUSTA, ME 04333

SHIP TO:
 State of Maine Motor Transport
 26 State House Station
 (Mdot) Attn: T. Sirois
 AUGUSTA, ME 04333

CUSTOMER NUMBER	CUSTOMER ORDER NUMBER	RELEASE NUMBER	SALESPERSON	
1797	V/R Two Tank Sys.		David Blanchette	
WRITER	SHIP VIA	TERMS	SHIP DATE	PHONE
David Blanche	PK PICKUP	Net Due 20 Days	04/01/15	207-287-2543

ORDER QTY	PART NO	DESCRIPTION	UNIT PRICE	NET AMOUNT
		Hole. - CARB EVR-Approved		
1ea	305XPA2400	305XPA-2400AKEVR Morrison Brothers 2" Tank Monitor Cap/Adaptor w/ - Cable Connector - 1/2" Hole - CARB/EVR Approved	55.040	55.04
1ea	794380-208	794380-208 Veeder Root Piping Sump Sensor W/ 12' Cable.	209.700	209.70
1ea	794390-420	794390-420 Veeder Root Steel Tank Interstitial Sensor w/ 16' Cable.	370.800	370.80
1ea	848940-005	848940-005 Veeder Root Inform 1 - 5 Sites Inform PC Software. ** Special Order NON-Returnable **	1285.200	1285.20
1ea	790095-001	790095-001 Veeder Root Overfill Alarm Acknowledgement Switch.	345.600	345.60
1ea	790091-001	790091-001 Veeder Root Audible / Visual Overfill Alarm.	544.500	544.50
TAXES NOT INCLUDED				

*** This is a quotation ***

Prices are firm for 30 days and subject to
 change without notice after 30 days.

Applicable taxes extra!

Subtotal	13328.70
S&H CHGS	55.00
Amount Due	13383.70

John W. Kennedy Company - ME
 51 Carey Circle
 HAMPDEN, ME 04444
 207-942-0767 Fax 207-942-3197

Quotation

QUOTE DATE	QUOTE NUMBER
04/03/15	S1462093
ORDER TO: John W. Kennedy Company - ME 51 Carey Circle HAMPDEN, ME 04444 207-942-0767 Fax 207-942-3197	
PAGE NO. 1	

QUOTE TO:
 State of Maine Motor Transport Svc.
 26 State House Station
 (Mdot) Attn: T. Sirois
 AUGUSTA, ME 04333

SHIP TO:
 State of Maine Motor Transport
 26 State House Station
 (Mdot) Attn: T. Sirois
 AUGUSTA, ME 04333

CUSTOMER NUMBER	CUSTOMER ORDER NUMBER	RELEASE NUMBER	SALESPERSON	
1797	Dual Compartment Bid	8000 Gallon 4/4	David Blanchette	
WRITER	SHIP VIA	TERMS	SHIP DATE	PHONE
David Blanche	DIRECT	Net Due 20 Days	04/03/15	207-287-2543
ORDER QTY	PART NO	DESCRIPTION	UNIT PRICE	NET AMOUNT
		***** All tanks listed below include the following option: * UL-2085 Fireguard Cylindrical * UL-142 Listing * (2) 6" High UL Saddle Supports * 24" UL Above Liquid Manway * Primary and Secondary E-Vents * Suction Opening w/Plumbing to a Cabinet Dispenser Mounted at the End of the Tank. * 60" x 60"Dispenser Containment Deck. 25 Gallon plus reservoir. * Fill Opening with a 3" Ground Level Remote Fill Box, Attached to the end of the tank. * Morrison Overfill Valve and Drop Tube. * Normal vent opening w/riser pipe and cover. * Morrison Level Gauge * Interstitial Opening with Mechanical Leak Indicator. * 60" Long Canopy w/ Pipe Sleeve and coupling. * Wire Trough Attached to tank. * Identifying Labels and Placards * Interior of the Tank Swept Clean. * Exterior of the tank to be abrasive blasted, primed and finished with Ivory Epoxy.		
*** Continued on Next Page ***				

John W. Kennedy Company - ME
51 Carey Circle
HAMPDEN, ME 04444
207-942-0767 Fax 207-942-3197

Quotation

QUOTE DATE	QUOTE NUMBER
04/03/15	S1462093
ORDER TO: John W. Kennedy Company - ME 51 Carey Circle HAMPDEN, ME 04444 207-942-0767 Fax 207-942-3197	PAGE NO. 2

QUOTE TO:
 State of Maine Motor Transport Svc.
 26 State House Station
 (Mdot) Attn: T. Sirois
 AUGUSTA, ME 04333

SHIP TO:
 State of Maine Motor Transport
 26 State House Station
 (Mdot) Attn: T. Sirois
 AUGUSTA, ME 04333

CUSTOMER NUMBER	CUSTOMER ORDER NUMBER	RELEASE NUMBER	SALESPERSON	
1797	Dual Compartment Bid	8000 Gallon 4/4	David Blanchette	
WRITER	SHIP VIA	TERMS	SHIP DATE	PHONE
David Blanche	DIRECT	Net Due 20 Days	04/03/15	207-287-2543

ORDER QTY	PART NO	DESCRIPTION	UNIT PRICE	NET AMOUNT
2ea	9153KX	* All Piping to be finished with Ivory Epoxy. * Factory Installation of Gasboy Dispenser. * Factory Installation of FE Petro Sub Pump. * All Piping Welded of Flanged * All Valves Pipes and Fittings for Above Equipment. 9153KX F Gasboy Atlas 1-Product 1-Hose High Speed Dispenser w/ Internal Filter Adapter and Standard Element. Includes the following options: * Light * 10:1 Pulser * All Stainless Steel Panels		
2ea	GB-LOWHOSE	GB-LOWHOSE-FREIGHTIN Gilbarco Low Hose Pump / Dispenser Units Freight-In Surcharge.		
1ea	5323273320	53232733201569 Goodyear 1" x 14' Flexsteel Hose w/ Chrome Ends.		
1ea	5323273240	53232732401569 Goodyear 3/4" x 14' Flexsteel Hose w/ Chrome Ends		
1ea	66-1300	66-1300 OPW 1" Breakaway Valve, W/ Whip Hose.		
1ea	66-0075	66-0075 OPW 3/4" Breakaway w/ 9" Hose.		

*** Continued on Next Page ***

John W. Kennedy Company - ME
51 Carey Circle
HAMPDEN, ME 04444
207-942-0767 Fax 207-942-3197

Quotation

QUOTE DATE	QUOTE NUMBER
04/03/15	S1462093
ORDER TO: John W. Kennedy Company - ME 51 Carey Circle HAMPDEN, ME 04444 207-942-0767 Fax 207-942-3197	PAGE NO. 3

QUOTE TO:
 State of Maine Motor Transport Svc.
 26 State House Station
 (Mdot) Attn: T. Sirois
 AUGUSTA, ME 04333

SHIP TO:
 State of Maine Motor Transport
 26 State House Station
 (Mdot) Attn: T. Sirois
 AUGUSTA, ME 04333

CUSTOMER NUMBER	CUSTOMER ORDER NUMBER	RELEASE NUMBER	SALESPERSON	
1797	Dual Compartment Bid	8000 Gallon 4/4	David Blanchette	
WRITER	SHIP VIA	TERMS	SHIP DATE	PHONE
David Blanche	DIRECT	Net Due 20 Days	04/03/15	207-287-2543

ORDER QTY	PART NO	DESCRIPTION	UNIT PRICE	NET AMOUNT
1ea	7H-0100	7H-0100 OPW 1" Hi-Flow Nozzle W/ Flowlock Ball Check, Green Hand Warmer, With Spout Ring.		
1ea	11BP-0400	11BP-0400 OPW 11B Unlead Nozzle w/ Black Handwarmer.		
1ea	45-5075	45-5075 OPW 1" x 1" Hose Swivel.		
1ea	45-5060	45-5060 OPW 3/4" Hose Swivel.		
2ea	402066901	402066901 FE Petro STP75VL2R 3/4hp Variable Length Submerged Turbine Pump - Range: 86"- 149" - ** Special Order NON-Returnable **		
2ea	400818921	400818921 FE Petro STP-CBS Control Box w/ Switch and Lock-out.		
1ea	MW-8K8-FG	MW-8K8-FG Modern Welding 8,000 Gallon 8'Dia. x 22' Long Cylindrical Fireguard Tank w/ Includes the following options: * Double Wall Bulkhead * Tank to be split 4/4 ** Special Order NON-Returnable **		
1ea	24163	Misc Taxable Product		
8000 Gallon Fireguard Subtotal				74042.61
TAXES NOT INCLUDED				

*** This is a quotation ***

Prices are firm for 30 days and subject to
 change without notice after 30 days.

Applicable taxes extra!

Subtotal	74042.61
S&H CHGS	0.00
Amount Due	74042.61

John W. Kennedy Company - ME
 51 Carey Circle
 HAMPDEN, ME 04444
 207-942-0767 Fax 207-942-3197

Quotation

QUOTE DATE		QUOTE NUMBER	
04/03/15		S1462091	
ORDER TO:			PAGE NO.
John W. Kennedy Company - ME 51 Carey Circle HAMPDEN, ME 04444 207-942-0767 Fax 207-942-3197			1

QUOTE TO:
 State of Maine Motor Transport Svc.
 26 State House Station
 (Mdot) Attn: T. Sirois
 AUGUSTA, ME 04333

SHIP TO:
 State of Maine Motor Transport
 26 State House Station
 (Mdot) Attn: T. Sirois
 AUGUSTA, ME 04333

CUSTOMER NUMBER	CUSTOMER ORDER NUMBER	RELEASE NUMBER	SALESPERSON	
1797	Dual Compartment Bid	12000 Gallon 8/4	David Blanchette	
WRITER	SHIP VIA	TERMS	SHIP DATE	PHONE
David Blanche	DIRECT	Net Due 20 Days	04/03/15	207-287-2543
ORDER QTY	PART NO	DESCRIPTION	UNIT PRICE	NET AMOUNT
		***** All tanks listed below include the following option: * UL-2085 Fireguard Cylindrical * UL-142 Listing * (2) 6" High UL Saddle Supports * 24" UL Above Liquid Manway * Primary and Secondary E-Vents * Suction Opening w/Plumbing to a Cabinet Dispenser Mounted at the End of the Tank. * 60" x 60"Dispenser Containment Deck. 25 Gallon plus reservoir. * Fill Opening with a 3" Ground Level Remote Fill Box, Attached to the end of the tank. * Morrison Overfill Valve and Drop Tube. * Normal vent opening w/riser pipe and cover. * Morrison Level Gauge * Interstitial Opening with Mechanical Leak Indicator. * 60" Long Canopy w/ Pipe Sleeve and coupling. * Wire Trough Attached to tank. * Identifying Labels and Placards * Interior of the Tank Swept Clean. * Exterior of the tank to be abrasive blasted, primed and finished with Ivory Epoxy.		
*** Continued on Next Page ***				

John W. Kennedy Company - ME
51 Carey Circle
HAMPDEN, ME 04444
207-942-0767 Fax 207-942-3197

Quotation

QUOTE DATE	QUOTE NUMBER
04/03/15	S1462091
ORDER TO: John W. Kennedy Company - ME 51 Carey Circle HAMPDEN, ME 04444 207-942-0767 Fax 207-942-3197	PAGE NO. 2

QUOTE TO:
 State of Maine Motor Transport Svc.
 26 State House Station
 (Mdot) Attn: T. Sirois
 AUGUSTA, ME 04333

SHIP TO:
 State of Maine Motor Transport
 26 State House Station
 (Mdot) Attn: T. Sirois
 AUGUSTA, ME 04333

CUSTOMER NUMBER	CUSTOMER ORDER NUMBER	RELEASE NUMBER	SALESPERSON	
1797	Dual Compartment Bid	12000 Gallon 8/4	David Blanchette	
WRITER	SHIP VIA	TERMS	SHIP DATE	PHONE
David Blanche	DIRECT	Net Due 20 Days	04/03/15	207-287-2543

ORDER QTY	PART NO	DESCRIPTION	UNIT PRICE	NET AMOUNT
2ea	9153KX	* All Piping to be finished with Ivory Epoxy. * Factory Installation of Gasboy Dispenser. * Factory Installation of FE Petro Sub Pump. * All Piping Welded of Flanged * All Valves Pipes and Fittings for Above Equipment. 9153KX F Gasboy Atlas 1-Product 1-Hose High Speed Dispenser w/ Internal Filter Adapter and Standard Element. Includes the following options: * Light * 10:1 Pulser * All Stainless Steel Panels		
2ea	GB-LOWHOSE	GB-LOWHOSE-FREIGHTIN Gilbarco Low Hose Pump / Dispenser Units Freight-In Surcharge.		
1ea	5323273320	53232733201569 Goodyear 1" x 14' Flexsteel Hose w/ Chrome Ends.		
1ea	5323273240	53232732401569 Goodyear 3/4" x 14' Flexsteel Hose w/ Chrome Ends		
1ea	66-1300	66-1300 OPW 1" Breakaway Valve, W/ Whip Hose.		
1ea	66-0075	66-0075 OPW 3/4" Breakaway w/ 9" Hose.		

*** Continued on Next Page ***

John W. Kennedy Company - ME
51 Carey Circle
HAMPDEN, ME 04444
207-942-0767 Fax 207-942-3197

Quotation

QUOTE DATE	QUOTE NUMBER
04/03/15	S1462091
ORDER TO: John W. Kennedy Company - ME 51 Carey Circle HAMPDEN, ME 04444 207-942-0767 Fax 207-942-3197	PAGE NO. 3

QUOTE TO:
 State of Maine Motor Transport Svc.
 26 State House Station
 (Mdot) Attn: T. Sirois
 AUGUSTA, ME 04333

SHIP TO:
 State of Maine Motor Transport
 26 State House Station
 (Mdot) Attn: T. Sirois
 AUGUSTA, ME 04333

CUSTOMER NUMBER	CUSTOMER ORDER NUMBER	RELEASE NUMBER	SALESPERSON
1797	Dual Compartment Bid	12000 Gallon 8/4	David Blanchette
WRITER	SHIP VIA	TERMS	SHIP DATE
David Blanche	DIRECT	Net Due 20 Days	04/03/15
			207-287-2543

ORDER QTY	PART NO	DESCRIPTION	UNIT PRICE	NET AMOUNT
1ea	7H-0100	7H-0100 OPW 1" Hi-Flow Nozzle W/ Flowlock Ball Check, Green Hand Warmer, With Spout Ring.		
1ea	11BP-0400	11BP-0400 OPW 11B Unlead Nozzle w/ Black Handwarmer.		
1ea	45-5075	45-5075 OPW 1" x 1" Hose Swivel.		
1ea	45-5060	45-5060 OPW 3/4" Hose Swivel.		
2ea	402066901	402066901 FE Petro STP75VL2R 3/4hp Variable Length Submerged Turbine Pump - Range: 86"- 149" - ** Special Order NON-Returnable **		
2ea	400818921	400818921 FE Petro STP-CBS Control Box w/ Switch and Lock-out.		
1ea	MW-12K8-FG	MW-12K8-FG Modern Welding 12,000 Gallon 8'Dia x 32'5" Long Cylindrical Fireguard Tank w/ Includes the following options: * Double Wall Bulkhead * Tank to be split 8/4		
1ea	24163	Misc Taxable Product		
12000 Gallon Fireguard Subtotal				81177.06
TAXES NOT INCLUDED				
			Subtotal	81177.06
			S&H CHGS	0.00
			Amount Due	81177.06

*** This is a quotation ***

Prices are firm for 30 days and subject to
 change without notice after 30 days.

Applicable taxes extra!

John W. Kennedy Company - ME
 51 Carey Circle
 HAMPDEN, ME 04444
 207-942-0767 Fax 207-942-3197

Quotation

QUOTE DATE	QUOTE NUMBER
04/03/15	S1462064
ORDER TO: John W. Kennedy Company - ME 51 Carey Circle HAMPDEN, ME 04444 207-942-0767 Fax 207-942-3197	PAGE NO. 1

QUOTE TO:
 State of Maine Motor Transport Svc.
 26 State House Station
 (Mdot) Attn: T. Sirois
 AUGUSTA, ME 04333

SHIP TO:
 State of Maine Motor Transport
 26 State House Station
 (Mdot) Attn: T. Sirois
 AUGUSTA, ME 04333

CUSTOMER NUMBER	CUSTOMER ORDER NUMBER	RELEASE NUMBER	SALESPERSON	
1797	Dual Compartment Bid	12000 Gallon 6/6	David Blanchette	
WRITER	SHIP VIA	TERMS	SHIP DATE	PHONE
David Blanche	DIRECT	Net Due 20 Days	04/03/15	207-287-2543

ORDER QTY	PART NO	DESCRIPTION	UNIT PRICE	NET AMOUNT
		***** All tanks listed below include the following option: * UL-2085 Fireguard Cylindrical * UL-142 Listing * (2) 6" High UL Saddle Supports * 24" UL Above Liquid Manway * Primary and Secondary E-Vents * Suction Opening w/Plumbing to a Cabinet Dispenser Mounted at the End of the Tank. * 60" x 60"Dispenser Containment Deck. 25 Gallon plus reservoir. * Fill Opening with a 3" Ground Level Remote Fill Box, Attached to the end of the tank. * Morrison Overfill Valve and Drop Tube. * Normal vent opening w/riser pipe and cover. * Morrison Level Gauge * Interstitial Opening with Mechanical Leak Indicator. * 60" Long Canopy w/ Pipe Sleeve and coupling. * Wire Trough Attached to tank. * Identifying Labels and Placards * Interior of the Tank Swept Clean. * Exterior of the tank to be abrasive blasted, primed and finished with Ivory Epoxy.		

*** Continued on Next Page ***

John W. Kennedy Company - ME
51 Carey Circle
HAMPDEN, ME 04444
207-942-0767 Fax 207-942-3197

Quotation

QUOTE DATE	QUOTE NUMBER
04/03/15	S1462064
ORDER TO: John W. Kennedy Company - ME 51 Carey Circle HAMPDEN, ME 04444 207-942-0767 Fax 207-942-3197	PAGE NO. 2

QUOTE TO:
 State of Maine Motor Transport Svc.
 26 State House Station
 (Mdot) Attn: T. Sirois
 AUGUSTA, ME 04333

SHIP TO:
 State of Maine Motor Transport
 26 State House Station
 (Mdot) Attn: T. Sirois
 AUGUSTA, ME 04333

CUSTOMER NUMBER	CUSTOMER ORDER NUMBER	RELEASE NUMBER	SALESPERSON
1797	Dual Compartment Bid	12000 Gallon 6/6	David Blanchette
WRITER	SHIP VIA	TERMS	SHIP DATE
David Blanche	DIRECT	Net Due 20 Days	04/03/15
PHONE			
207-287-2543			

ORDER QTY	PART NO	DESCRIPTION	UNIT PRICE	NET AMOUNT
2ea	9153KX	* All Piping to be finished with Ivory Epoxy. * Factory Installation of Gasboy Dispenser. * Factory Installation of FE Petro Sub Pump. * All Piping Welded of Flanged * All Valves Pipes and Fittings for Above Equipment. 9153KX F Gasboy Atlas 1-Product 1-Hose High Speed Dispenser w/ Internal Filter Adapter and Standard Element. Includes the following options: * Light * 10:1 Pulser * All Stainless Steel Panels		
2ea	GB-LOWHOSE	GB-LOWHOSE-FREIGHTIN Gilbarco Low Hose Pump / Dispenser Units Freight-In Surcharge.		
1ea	5323273320	53232733201569 Goodyear 1" x 14' Flexsteel Hose w/ Chrome Ends.		
1ea	5323273240	53232732401569 Goodyear 3/4" x 14' Flexsteel Hose w/ Chrome Ends		
1ea	66-1300	66-1300 OPW 1" Breakaway Valve, W/ Whip Hose.		
1ea	66-0075	66-0075 OPW 3/4" Breakaway w/ 9" Hose.		

*** Continued on Next Page ***

John W. Kennedy Company - ME
51 Carey Circle
HAMPDEN, ME 04444
207-942-0767 Fax 207-942-3197

Quotation

QUOTE DATE	QUOTE NUMBER
04/03/15	S1462064
ORDER TO: John W. Kennedy Company - ME 51 Carey Circle HAMPDEN, ME 04444 207-942-0767 Fax 207-942-3197	PAGE NO. 3

QUOTE TO:
 State of Maine Motor Transport Svc.
 26 State House Station
 (Mdot) Attn: T. Sirois
 AUGUSTA, ME 04333

SHIP TO:
 State of Maine Motor Transport
 26 State House Station
 (Mdot) Attn: T. Sirois
 AUGUSTA, ME 04333

CUSTOMER NUMBER	CUSTOMER ORDER NUMBER	RELEASE NUMBER	SALESPERSON	
1797	Dual Compartment Bid	12000 Gallon 6/6	David Blanchette	
WRITER	SHIP VIA	TERMS	SHIP DATE	PHONE
David Blanche	DIRECT	Net Due 20 Days	04/03/15	207-287-2543

ORDER QTY	PART NO	DESCRIPTION	UNIT PRICE	NET AMOUNT
1ea	7H-0100	7H-0100 OPW 1" Hi-Flow Nozzle W/ Flowlock Ball Check, Green Hand Warmer, With Spout Ring.		
1ea	11BP-0400	11BP-0400 OPW 11B Unlead Nozzle w/ Black Handwarmer.		
1ea	45-5075	45-5075 OPW 1" x 1" Hose Swivel.		
1ea	45-5060	45-5060 OPW 3/4" Hose Swivel.		
2ea	402066901	402066901 FE Petro STP75VL2R 3/4hp Variable Length Submerged Turbine Pump - Range: 86"- 149" - ** Special Order NON-Returnable **		
2ea	400818921	400818921 FE Petro STP-CBS Control Box w/ Switch and Lock-out.		
1ea	MW-12K8-FG	MW-12K8-FG Modern Welding 12,000 Gallon 8'Dia x 32'5"Long Cylindrical Fireguard Tank w/ Includes the following options: * Double Wall Bulkhead * Tank to be split 6/6		
1ea	24163	Misc Taxable Product		
12000 Gallon Fireguard Subtotal				81182.46
TAXES NOT INCLUDED				

*** This is a quotation ***

Prices are firm for 30 days and subject to
 change without notice after 30 days.

Applicable taxes extra!

Subtotal	81182.46
S&H CHGS	0.00
Amount Due	81182.46

State of Maine Tank Bid Summary

Exceptions to this bid:

5.0 Air Tank Test

Will not be performed by distribution. Must be performed by licensed tank installer.

State of Maine Bid “Warranty”

WARRANTY: The Seller warrants all new equipment, if installed and operated in a proper manner, against defects in workmanship and material for 12 months from the date of shipment. Warranties and liabilities shall be limited to the Buyer, and shall not extend to the Buyer's vendees. The Seller's liability will not extend beyond the description on the face hereof. In no event shall the Seller's liability exceed the purchase price of the equipment. Damage caused by chemical reaction, electrolytic action or foreign materials are to be assumed by the Buyer, and in no way are they to be considered part of the warranty.

Upon notice of any defect by the Buyer, and confirmation by the Seller, the Seller shall have the right to furnish all material, and/or perform all labor, required for the correction of any errors or omissions on the part of the Seller, and no charge will be allowed for any material furnished or labor performed by the Purchaser, or others, unless the Seller is given sufficient written notice and a written order is issued by the Seller for such material and/or labor.

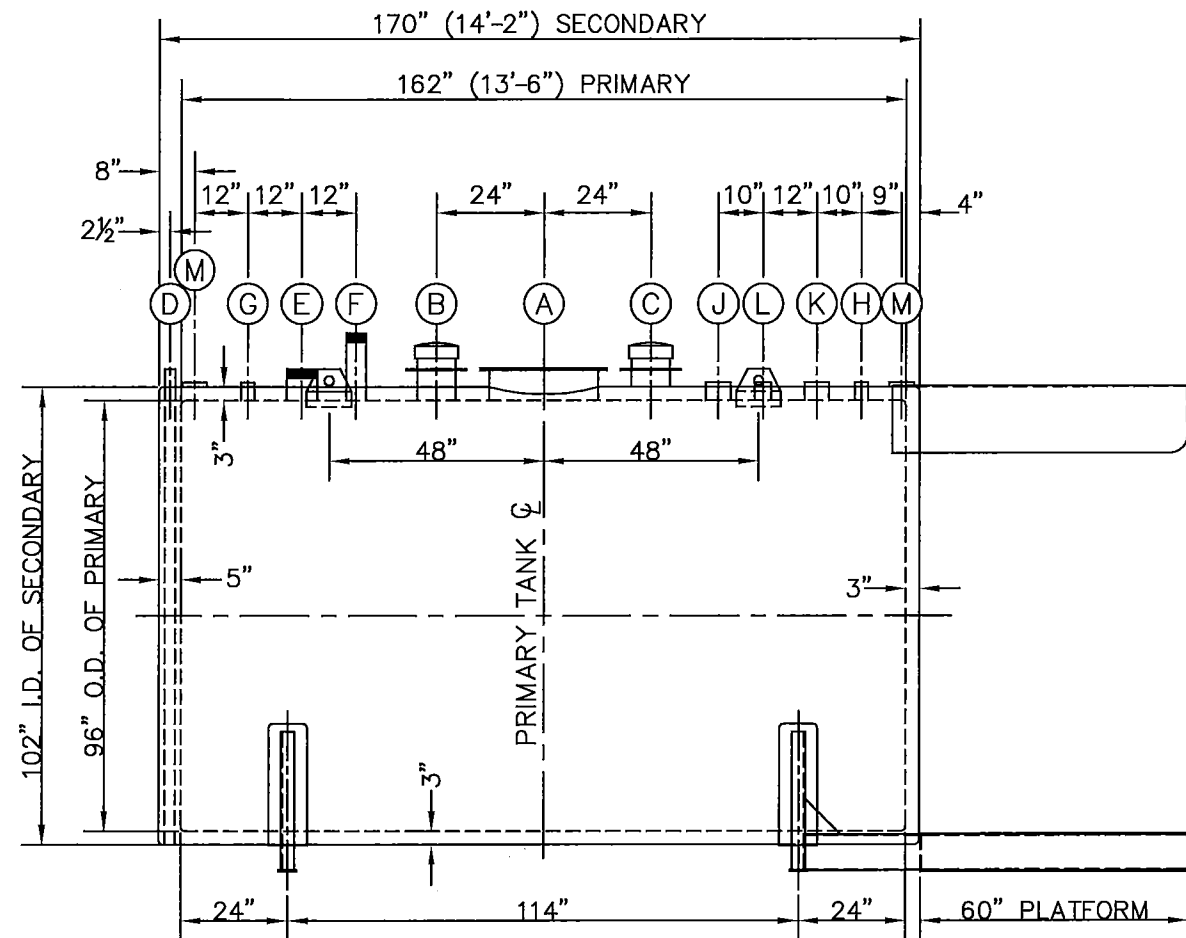

ELEVATION VIEW

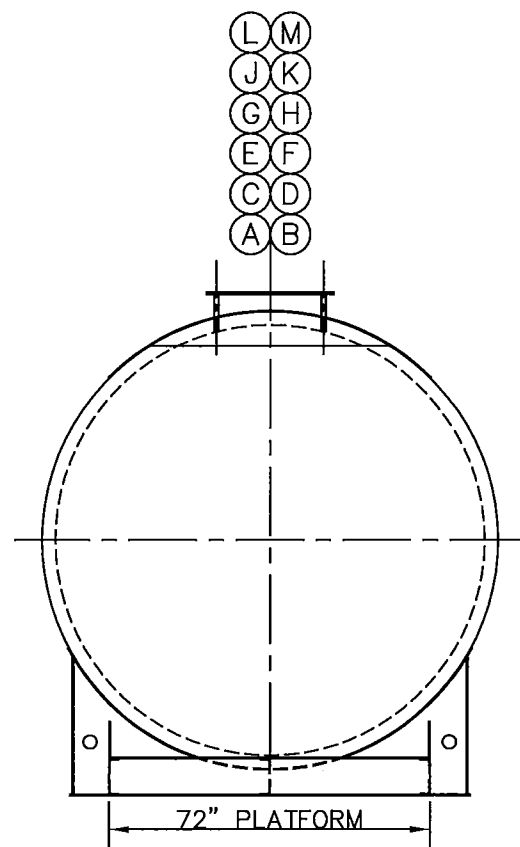

DISPENSER END VIEW

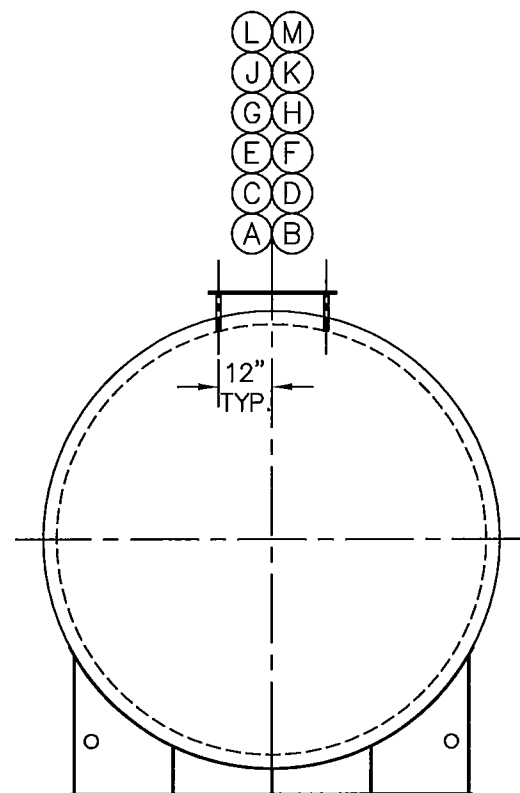

FILL END VIEW

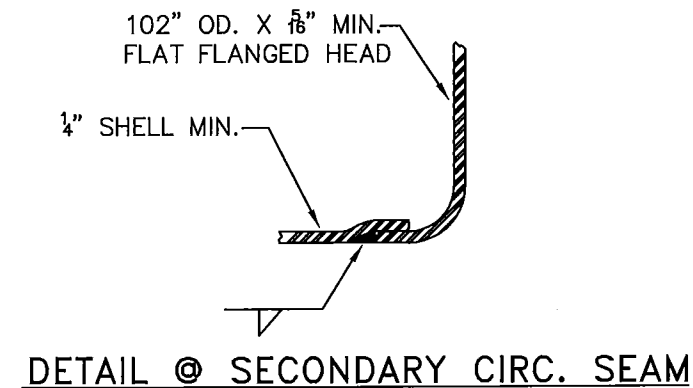
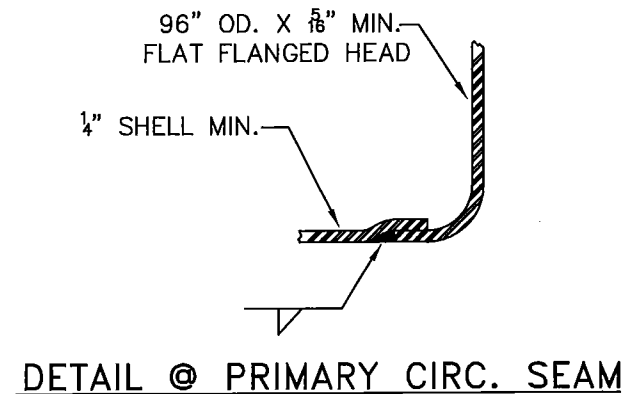
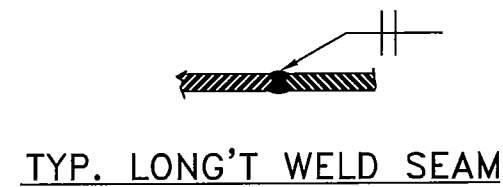

GENERAL NOTES

FABRICATION PER: UL-142 & UL-2085
 LABEL REQUIRED YES NO
 SHOP TEST: PER UL-142
 3-5 PSI AIR WITH SOAP SUDS
 INSPECTION BY: MODERN WELDING Q.C.
 MATERIAL SHELL: A36
 FLANGES: A105
 PIPE: A106B
 SUPPORTS: A36
 INT. APPURTENANCES: C.S.
 EXT. APPURTENANCES: C.S.
 BOLTS: 193-2H
 NUTS: 194-B7
 GASKETS: PER UL-142
 SURFACE PREP.:
 EXT.: SSPC-SP6
 INT.: NONE
 PAINT:
 EXT.: SW 4036 MILL IVORY
 PER MANUFACTURER'S RECOMMENDATION
 EST. WT. EMPTY: 14,000 LBS
 TANK VENTING CAPACITY (CFH): PRI.: 278,800
 TANK VENTING CAPACITY (CFH): SEC.: 298,100
 OPENINGS SHALL BE PROTECTED PER UL-142

NOTES:

ALL FILLET WELDS TO BE 1/4" MIN WHERE POSSIBLE UNLESS OTHERWISE NOTED.
 ALL NOZZLE AND MANWAY BOLT HOLES TO STRADDLE NORMAL CENTER LINES OR THEIR THEIR PARALLEL UNLESS OTHERWISE NOTED.
 EMERGENCY VENTING LABELS FOR PRIMARY TANK & ANNULAR SPACE ARE REQUIRED. LABEL SHALL BE ATTACHED NEXT TO OR BETWEEN BOTH EMERGENCY VENTS.

* EMERGENCY VENTS TO BE SUPPLIED BY MODERN WELDING.

PROPRIETARY DRAWING
 THIS DRAWING IS THE PROPERTY OF MODERN WELDING CO., INC. NEITHER THIS DRAWING NOR ANY DATA OR INFORMATION HEREIN MAY BE REPRODUCED, COPIED, USED FOR ANY PURPOSE WHATSOEVER, WITHOUT THE PRIOR WRITTEN PERMISSION OF MODERN WELDING CO., INC.

MARK	REQ'D.	SIZE	ITEM	RATING	TYPE	SERVICE
M	2	4"	TANK FLG	STD	CRV	CONCRETE FILL
L	1	3"	COUPLING	150#	FG	VENT
K	1	4"	COUPLING	150#	FG	SPARE
J	1	4"	COUPLING	150#	FG	PUMP
H	1	2"	COUPLING	150#	FG	RETURN
G	1	2"	COUPLING	150#	FG	GAUGE
F	1	4"	NIPPLE	SCH 40	T.O.E.	ELECTRONIC LEVEL
E	1	6"	NIPPLE	SCH 40	T.O.E.	FILL
D	1	2"	PIPE	SCH 40	T.O.E.	MONITOR
* C	1	8"	FLG ADPT	-	MB	SEC. EMER. VENT
* B	1	8"	FLG ADPT	-	MB	PRI. EMER. VENT
A	1	24"	PRESSED STEEL	-	STD	MANWAY

SCHEDULE OF OPENINGS

JS	JC	ORIGINAL ISSUE FOR APPROVAL	8/18/2014	△
BY	AP	REVISION	DATE	NO
NO. REQ'D ONE (1)		ITEM NO.		
MODERN WELDING CO. of OHIO INC. P.O. Box 4430 One Modern Way Newark, Ohio 43056 (740)344-9425				
JOHN W. KENNEDY CO. 5,000 GALLON HORIZONTAL FIREGAURD TANK				
DWN. BY	JS	DATE	8/18/2014	SCALE: None
CHK. BY	JC	JOB NO.	632101	DWG. NO. 632101 △
APR. BY		P.O. No.	S1427169	SHT. NO. 1 OF 6

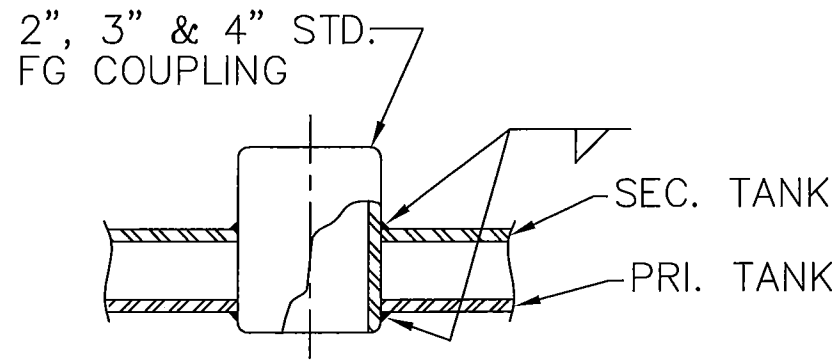

DETAIL @ COUPLINGS (G)(H)(J)(K)(L)

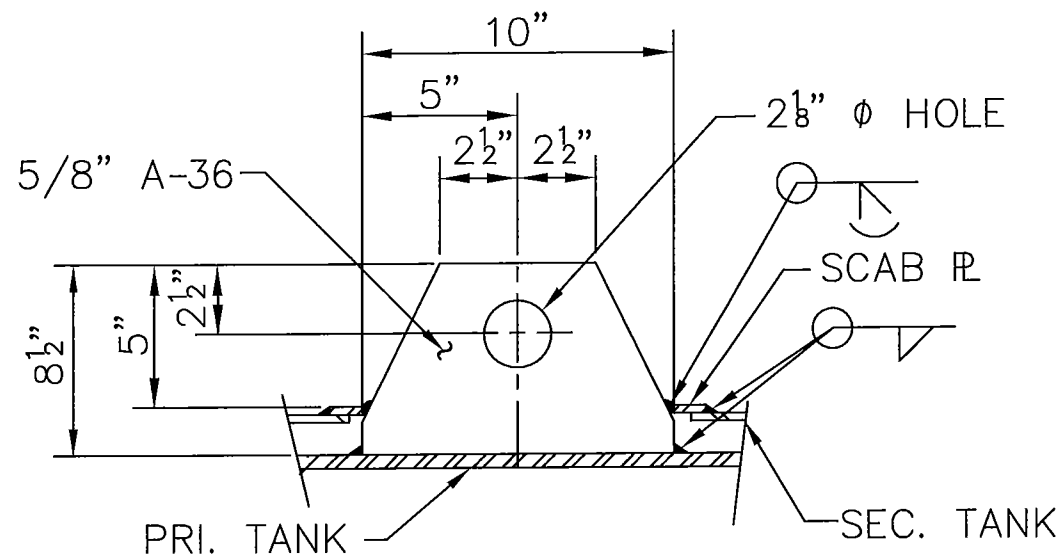

DETAIL @ LIFTING LUG
(2) REQ'D.

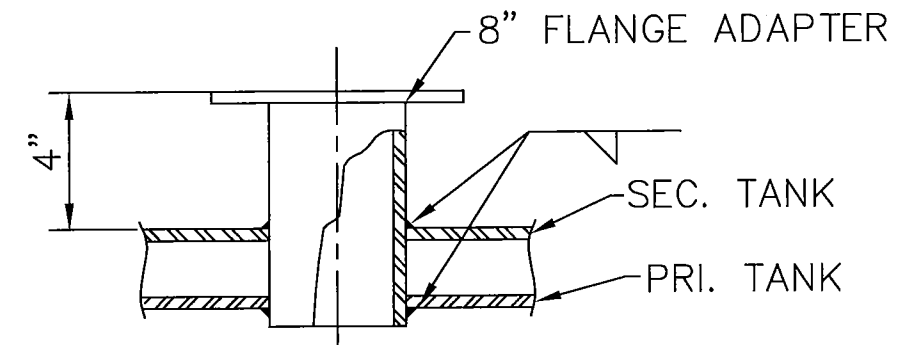

DETAIL @ PRI. EMER. VENT (B)

NOTE: CUT PRI. VENT TO CONTOUR OF PRI. TANK

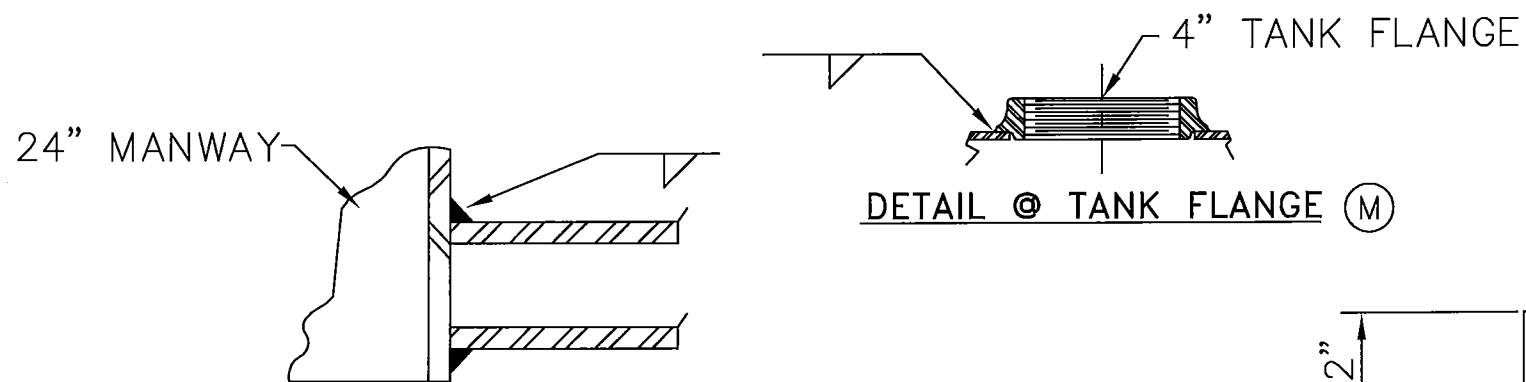

DETAIL @ MANWAY (A)

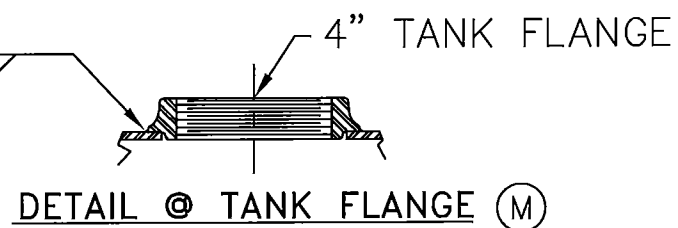

DETAIL @ TANK FLANGE (M)

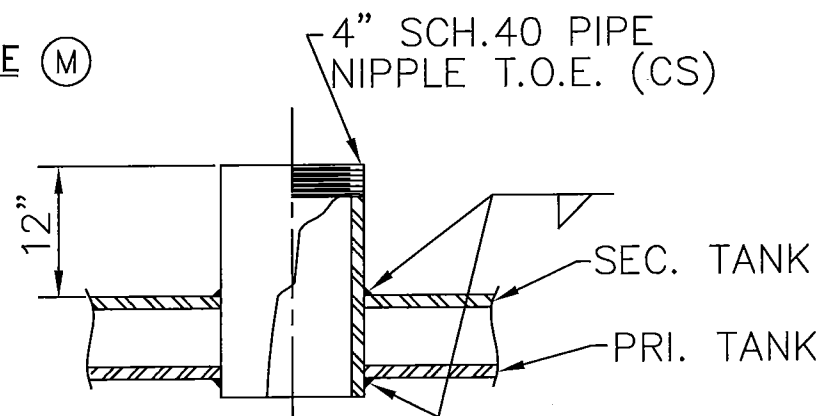

DETAIL @ PIPE NIPPLE (F)

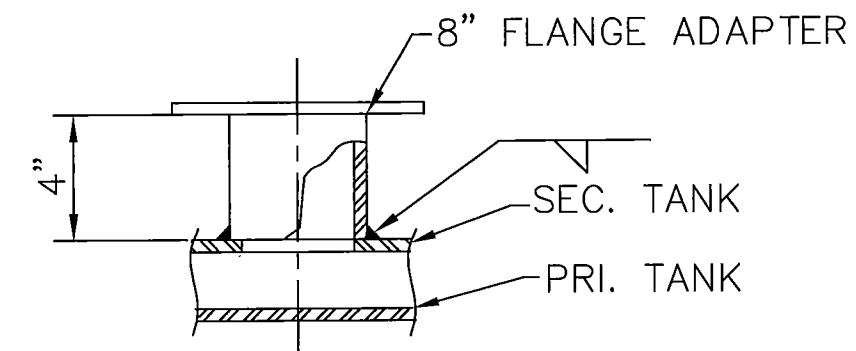

DETAIL @ SEC. EMER. VENT (C)

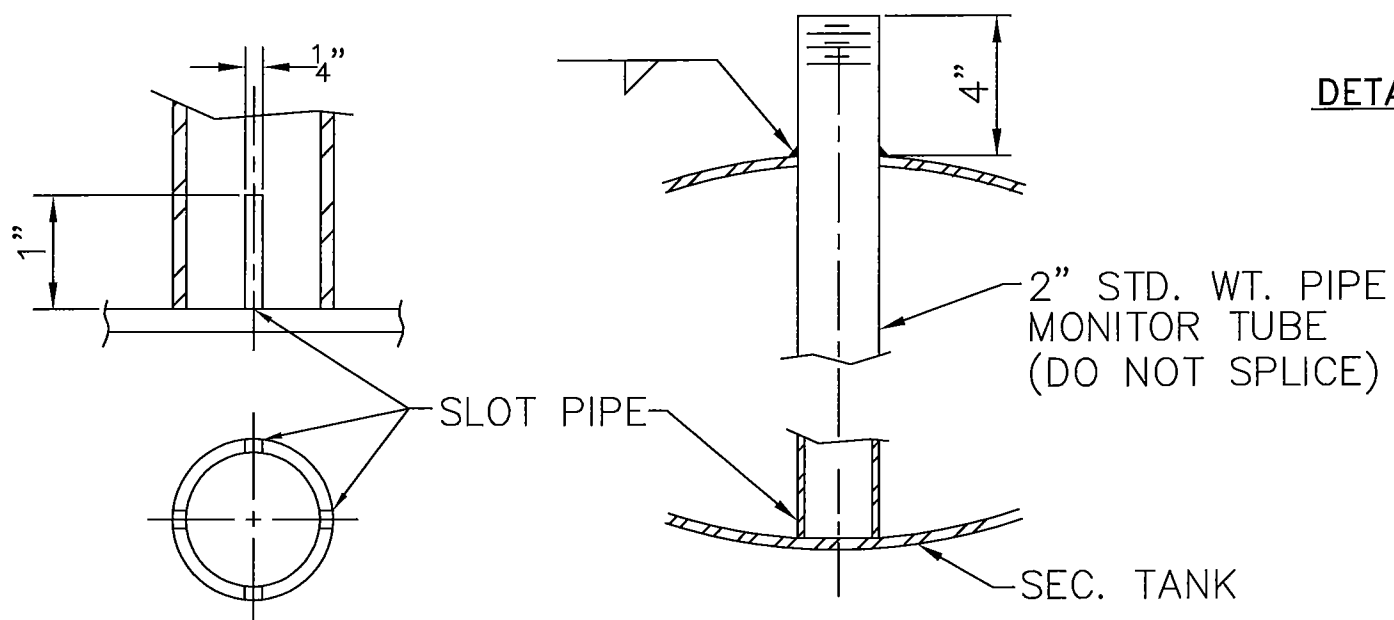

DETAIL @ MONITOR PIPE (D)

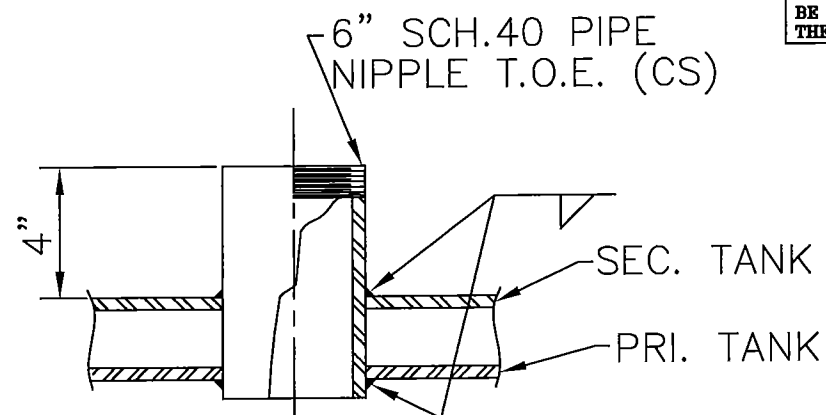

DETAIL @ FILL (E)

PROPRIETARY DRAWING
THIS DRAWING IS THE PROPERTY OF MODERN WELDING CO., INC.
NEITHER THIS DRAWING NOR ANY DATA OR INFORMATION HEREIN MAY
BE REPRODUCED, COPIED, USED FOR ANY PURPOSE WHATSOEVER, WITHOUT
THE PRIOR WRITTEN PERMISSION OF MODERN WELDING CO., INC.

JS/JC	ORIGINAL ISSUE FOR APPROVAL	8/18/2014	△
BY/AP	REVISION	DATE	NO
NO. REQ'D ONE (1)		ITEM NO.	
MODERN WELDING CO. of OHIO INC.			
P.O. Box 4430 One Modern Way		Newark, Ohio 43055 (740)344-9425	
JOHN W. KENNEDY CO.			
5,000 GALLON HORIZONTAL FIREGAURD TANK			
DWN. BY	JS	DATE 8/18/2014	SCALE: None
CHK. BY	JC	JOB NO. 632101	DWG. NO. 632101 △
APR. BY		P.O. NO. S1427169	SHT. NO. 2 OF 6

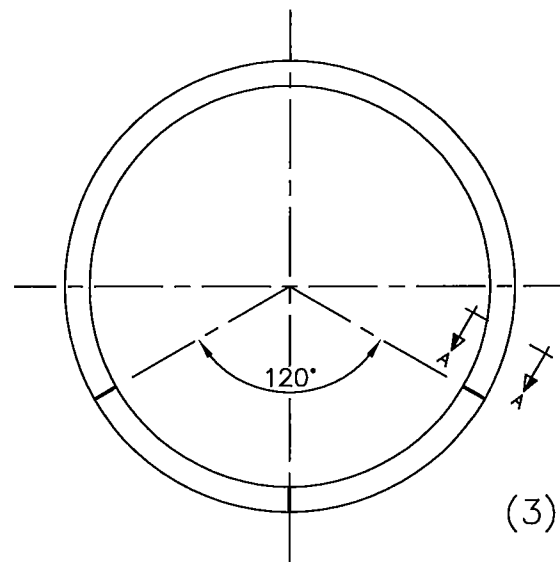

LAYOUT & SPACER PLATES

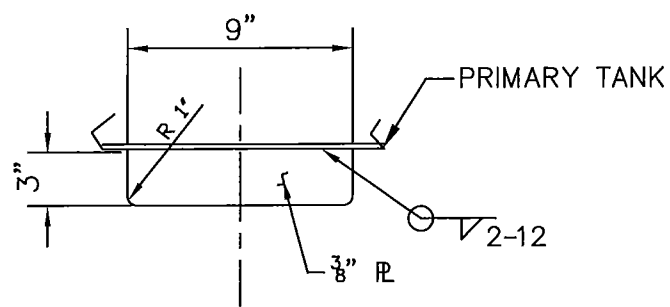

SECTION A-A

(3) REQ'D. CENTERED OVER EACH SADDLE

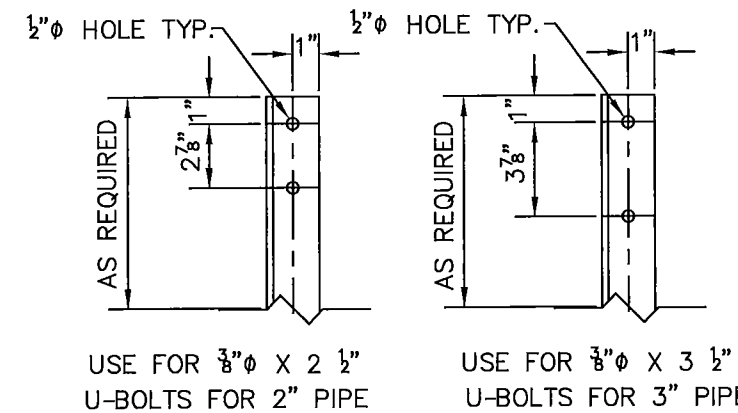

DETAIL @ PIPE SUPPORT

2"x2"x1/4" ANGLE

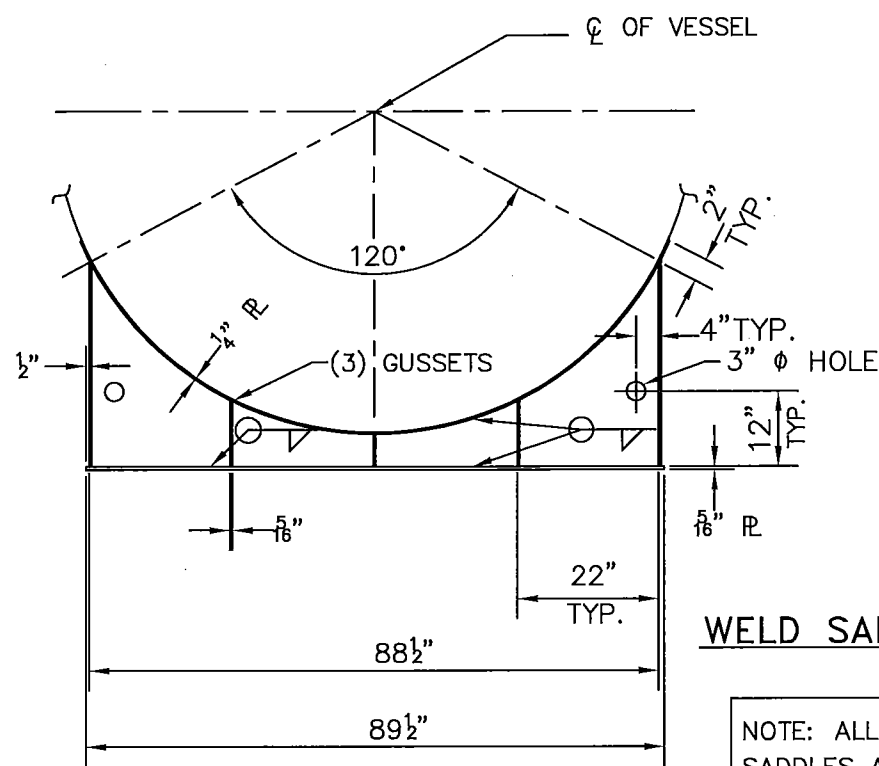

WELD SADDLES TO TANK

NOTE: ALL FILLET WELDS ON SADDLES ARE TO BE 1/8"

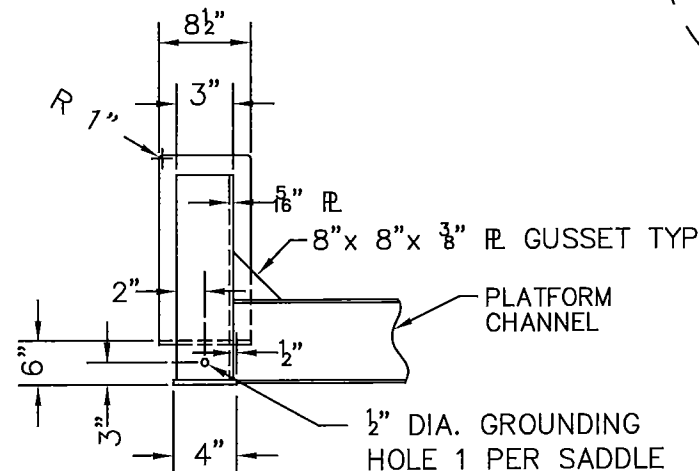

DETAIL "C"

FILL BOX TO BE PAINTED SAME COLOR AS TANK

CUSTOMER NOTE: GROUNDING LUG IS TO BE BOLTED AT THIS HOLE

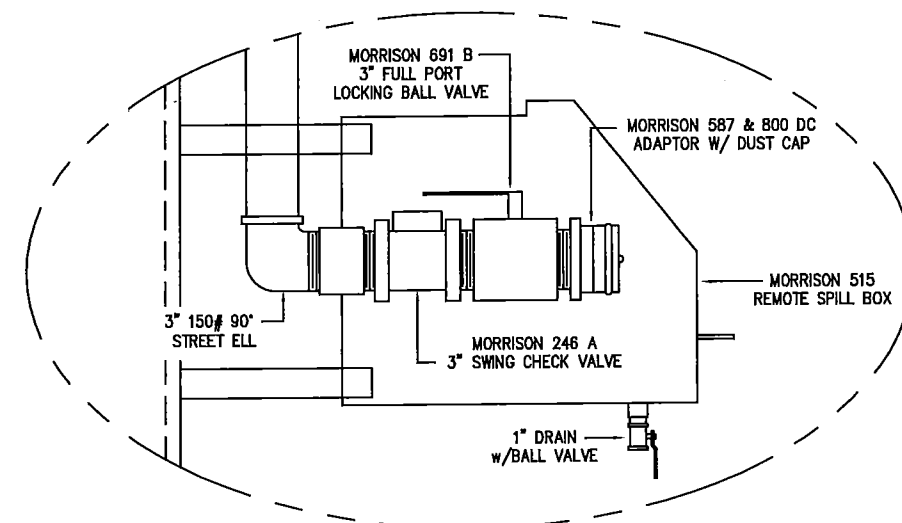

PROPRIETARY DRAWING
THIS DRAWING IS THE PROPERTY OF MODERN WELDING CO., INC. NEITHER THIS DRAWING NOR ANY DATA OR INFORMATION HEREIN MAY BE REPRODUCED, COPIED, USED FOR ANY PURPOSE WHATSOEVER, WITHOUT THE PRIOR WRITTEN PERMISSION OF MODERN WELDING CO., INC.

DETAIL @ SADDLE

(2) REQ'D

JS/JC	ORIGINAL ISSUE FOR APPROVAL	8/18/2014	△
BY/AP	REVISION	DATE	NO
NO. REQ'D ONE (1)		ITEM NO.	
MODERN WELDING CO. of OHIO INC.			
P.O. Box 4430 One Modern Way		Newark, Ohio 43055 (740)344-9425	
JOHN W. KENNEDY CO.			
5,000 GALLON HORIZONTAL FIREGAURD TANK			
DWN. BY	JS	DATE 8/18/2014	SCALE: None
CHK. BY	JC	JOB NO. 632101	DWG. NO. 632101 △
APR. BY		P.O. NO. S1427169	SHT. NO. 3 OF 6

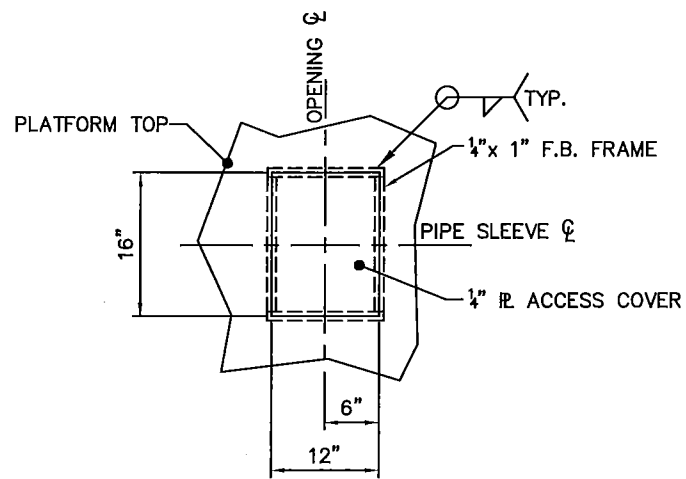

DETAIL @ ACCESS OPENING
(1) REQ'D.

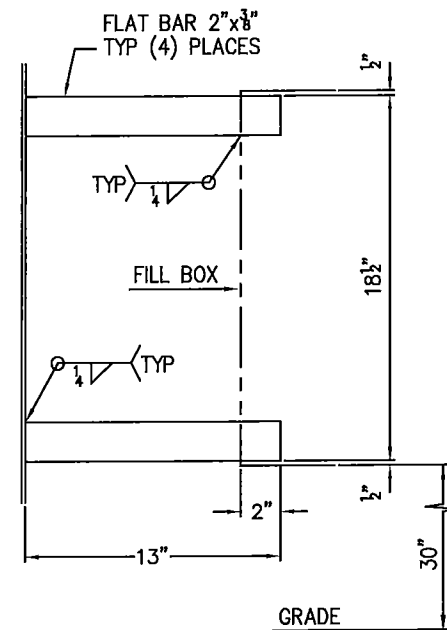

DETAIL @ FILL BOX BRACKET

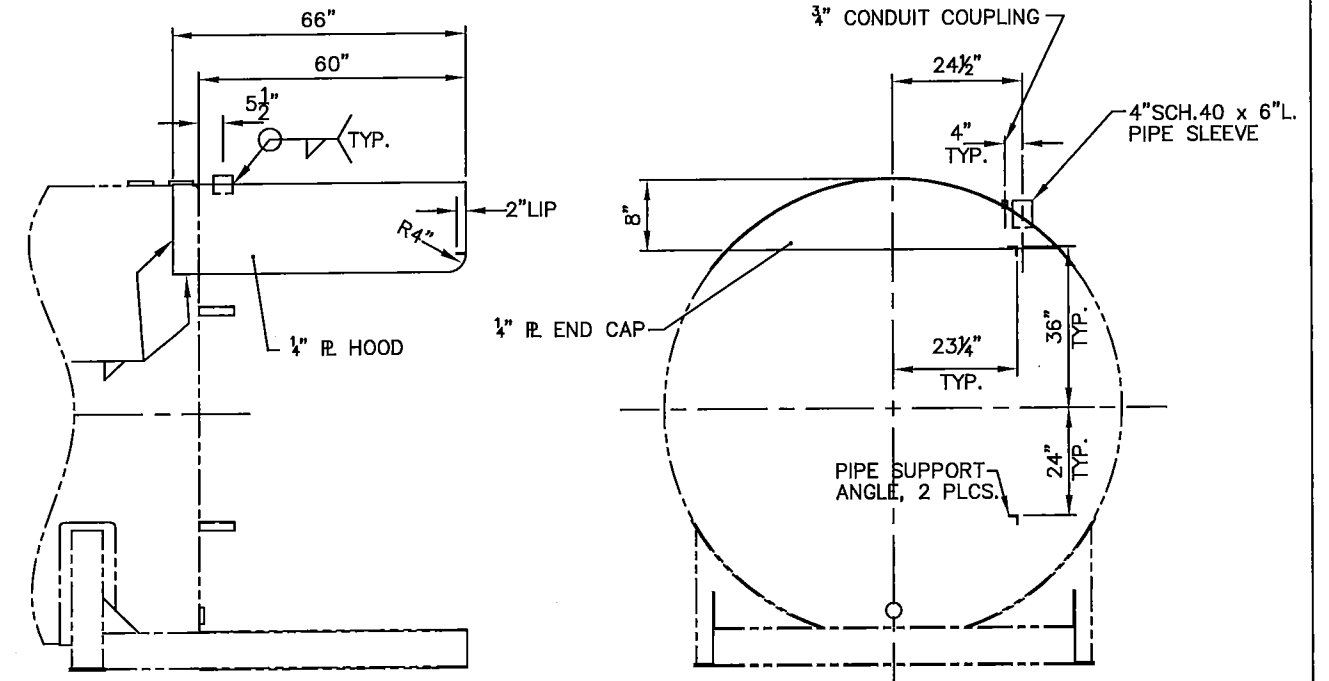

DETAIL @ RAIN HOOD

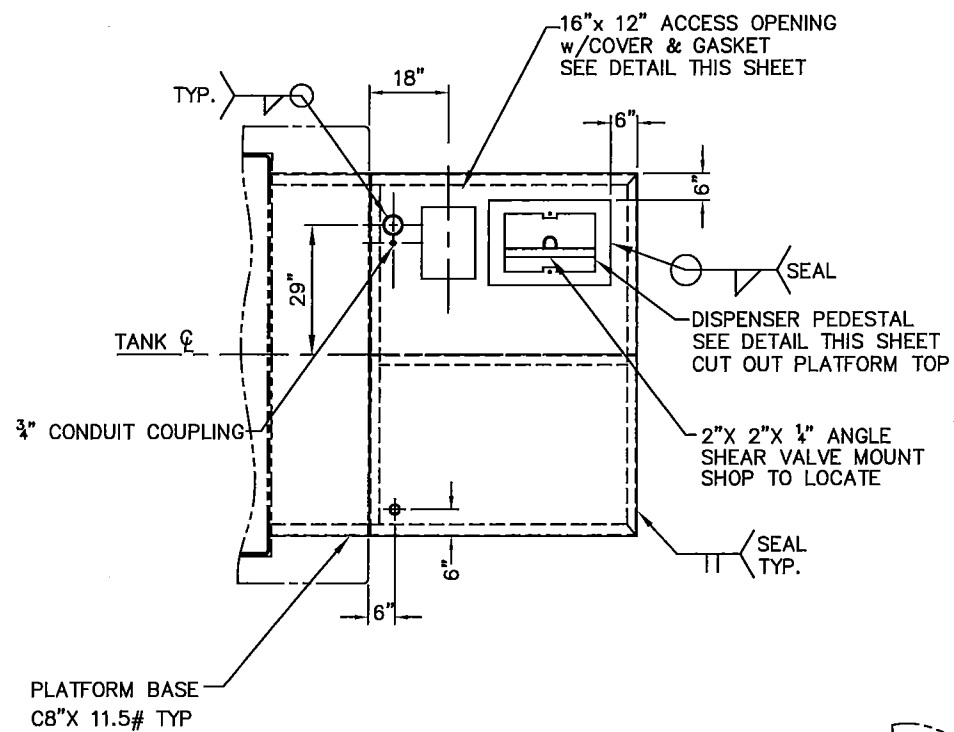

DETAIL @ CONTAINMENT PLATFORM

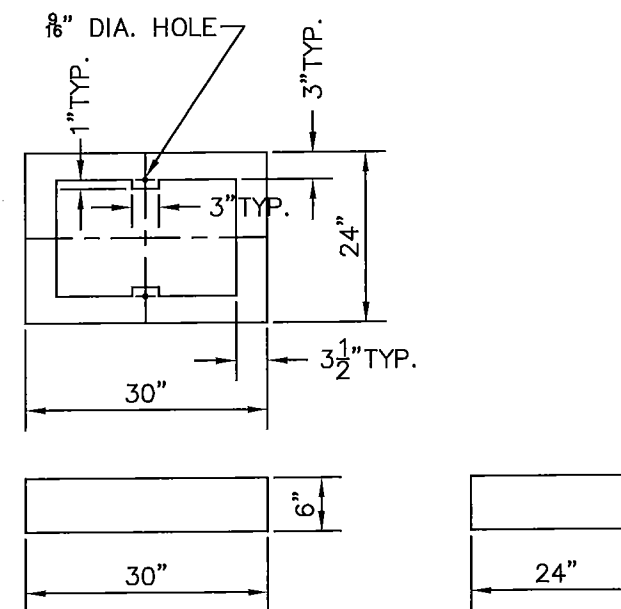

DETAIL @ PUMP PEDESTAL
(1) REQ'D.
7 GA. MATERIAL

PROPRIETARY DRAWING
THIS DRAWING IS THE PROPERTY OF MODERN WELDING CO., INC.
NEITHER THIS DRAWING NOR ANY DATA OR INFORMATION HEREIN MAY
BE REPRODUCED, COPIED, USED FOR ANY PURPOSE WHATSOEVER, WITHOUT
THE PRIOR WRITTEN PERMISSION OF MODERN WELDING CO., INC.

JS/JC	ORIGINAL ISSUE FOR APPROVAL	8/18/2014	0
BY/AP	REVISION	DATE	NO
NO. REQ'D	ONE (1)	ITEM NO.	
MODERN WELDING CO. of OHIO INC.			
P.O. Box 4430 One Modern Way		Newark, Ohio 43055 (740)344-9425	
JOHN W. KENNEDY CO.			
5,000 GALLON HORIZONTAL FIREGAURD TANK			
DWN. BY	JS	DATE	8/18/2014
SCALE:	None		
CHK. BY	JC	JOB NO.	632101
DWG. NO.	632101		
APR. BY		P.O. NO.	S1427169
SHT. NO.	4 OF 6		

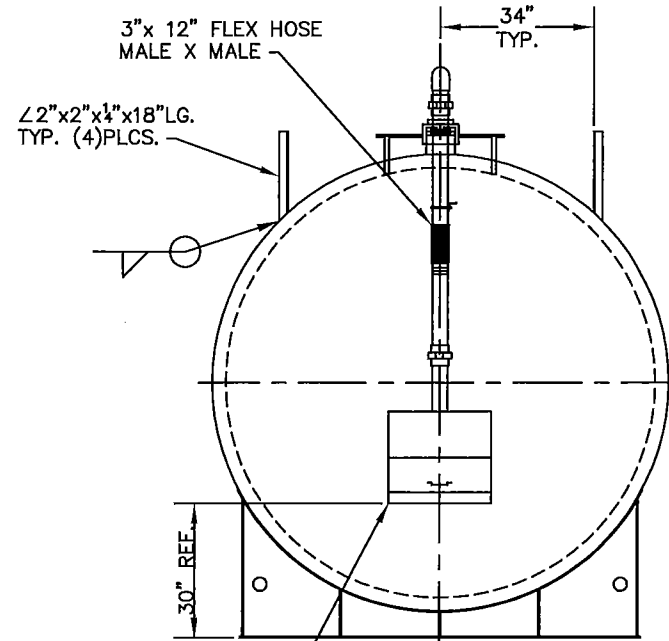

M.B. 515 REMOTE
FILL BOX w/
M.B. 691B 3" BALL VALVE,
M.B. 246A 3" CHECK VALVE,
M.B. 800F 3" MALE ADAPTOR
& M.B. 800DC 3" DUST CAP
(FILL BOX TO BE PAINTED
SAME COLOR AS TANK)

FILL END VIEW

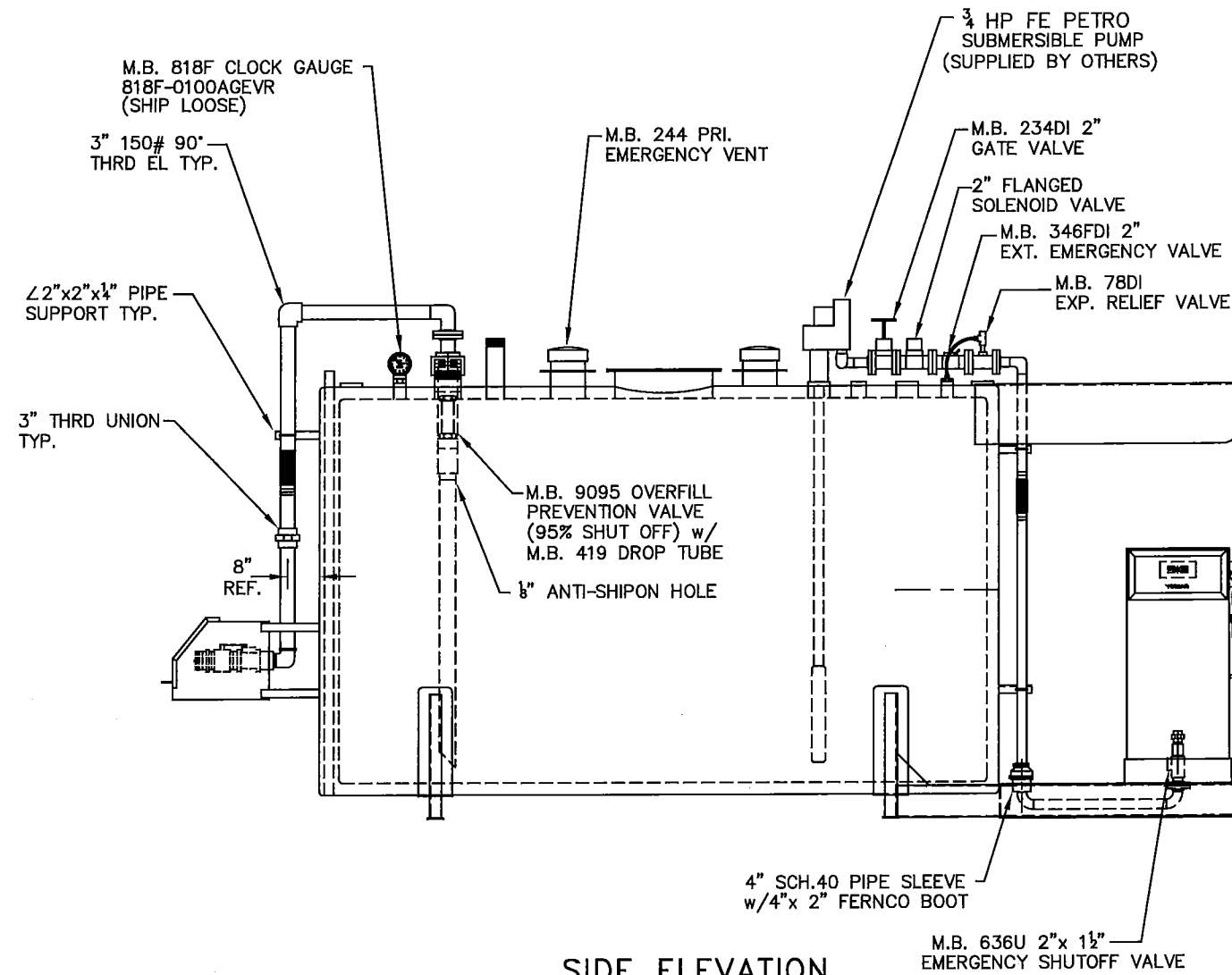

SIDE ELEVATION

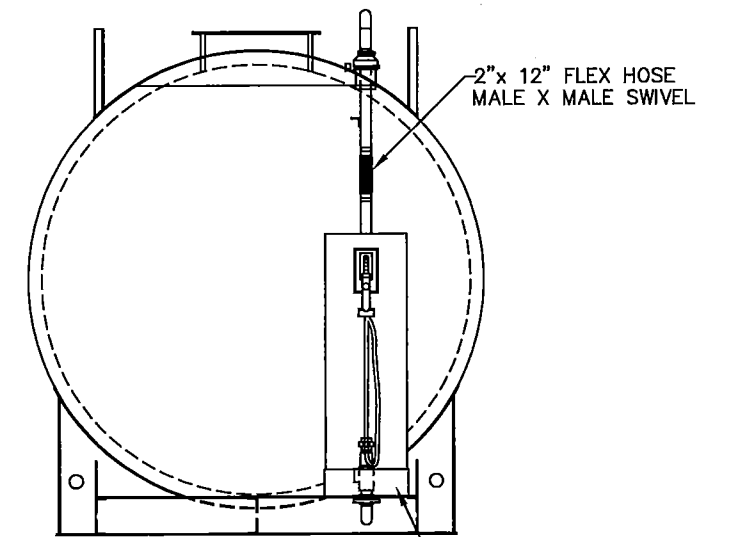

DISPENSER END VIEW

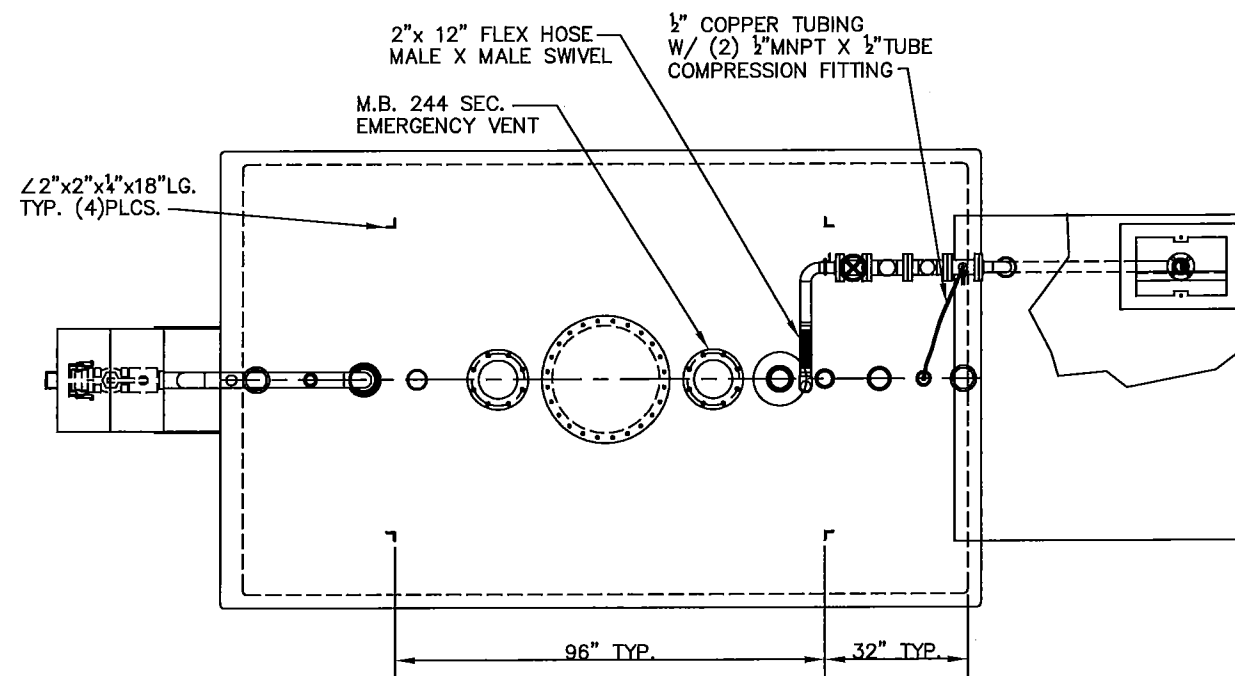

PLAN VIEW

PROPRIETARY DRAWING
THIS DRAWING IS THE PROPERTY OF MODERN WELDING CO., INC.
NEITHER THIS DRAWING NOR ANY DATA OR INFORMATION HEREIN MAY
BE REPRODUCED, COPIED, USED FOR ANY PURPOSE WHATSOEVER, WITHOUT
THE PRIOR WRITTEN PERMISSION OF MODERN WELDING CO., INC.

JS JC	ORIGINAL ISSUE FOR APPROVAL	8/18 2014	0
BY AP	REVISION	DATE	NO
NO. REQ'D ONE (1)		ITEM NO.	
MODERN WELDING CO. of OHIO INC.			
P.O. Box 4430 One Modern Way			Newark, Ohio 43055 (740)344-9425
JOHN W. KENNEDY CO.			
5,000 GALLON HORIZONTAL FIREGAURD TANK			
DWN. BY	JS	DATE 8/18/2014	SCALE: None
CHK. BY	JC	JOB NO. 632101	DWG. NO. 632101
APR. BY		P.O. NO. S1427169	SHT. NO. 5 OF 6

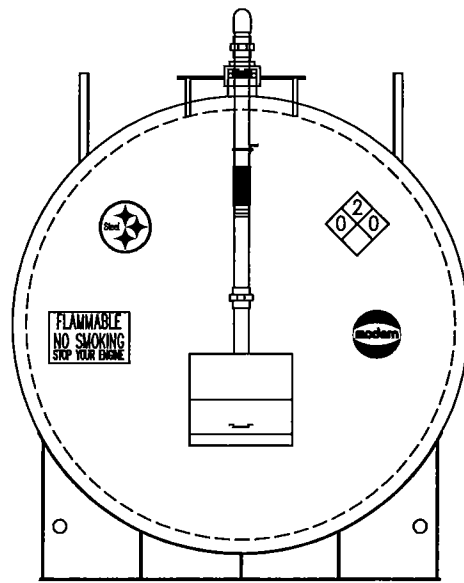

FILL END VIEW

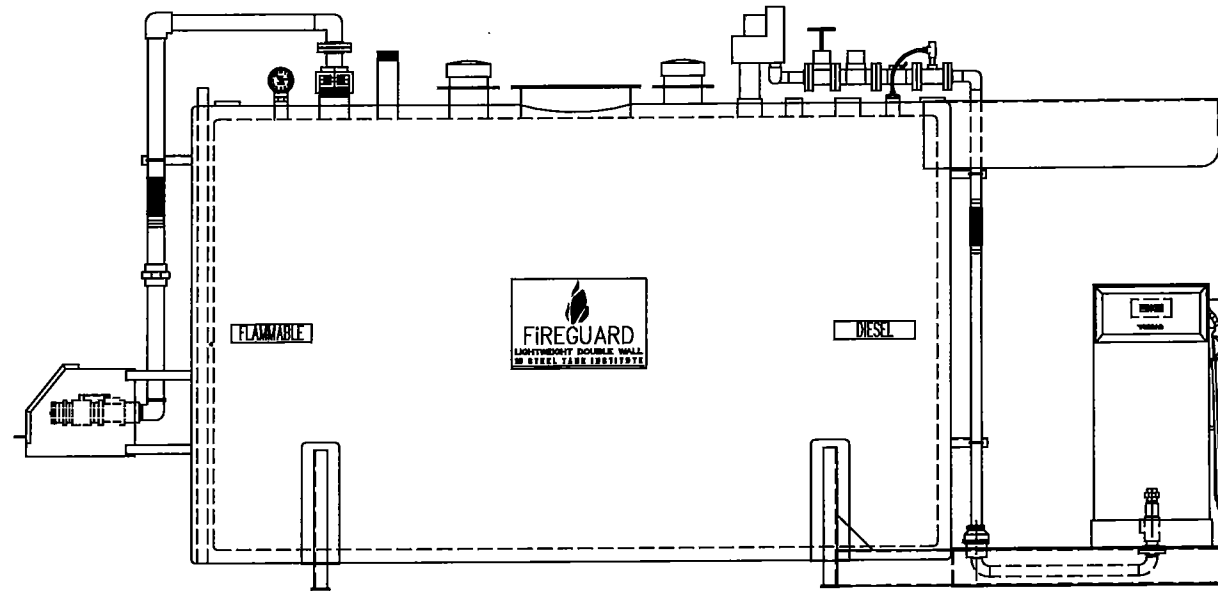

SIDE ELEVATION

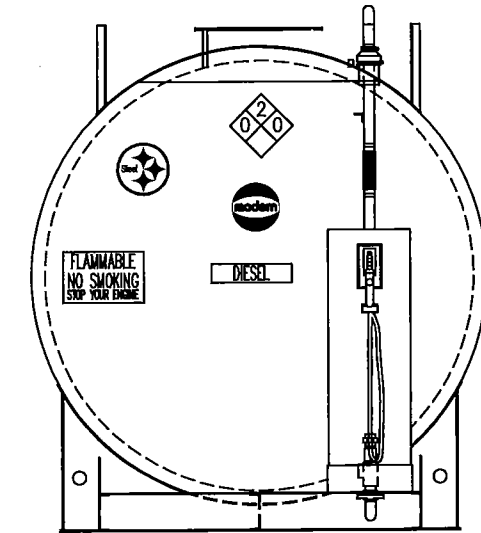

DISPENSER END VIEW

PROPRIETARY DRAWING
 THIS DRAWING IS THE PROPERTY OF MODERN WELDING CO., INC.
 NEITHER THIS DRAWING NOR ANY DATA OR INFORMATION HEREIN MAY
 BE REPRODUCED, COPIED, USED FOR ANY PURPOSE WHATSOEVER, WITHOUT
 THE PRIOR WRITTEN PERMISSION OF MODERN WELDING CO., INC.

JS JC	ORIGINAL ISSUE FOR APPROVAL	8/18 2014	△
BY AP	REVISION	DATE	NO
NO. REQ'D ONE (1)		ITEM NO.	
MODERN WELDING CO. of OHIO INC. P.O. Box 4430  Newark, Ohio 43055 One Modern Way (740)344-8425			
JOHN W. KENNEDY CO. 5,000 GALLON HORIZONTAL FIREGAURD TANK			
DWN. BY	JS	DATE 8/18/2014	SCALE: None
CHK. BY	JC	JOB NO. 632101	DWG. NO. 632101 △
APR. BY		P.O. NO. S1427169	SHT. NO. 6 OF 6



MODERN WELDING Co., INC.

ABOVEGROUND

SYSTEMS

TECHNOLOGY



AST

SYSTEMS TECHNOLOGY...
The Modern Way.

The Answers to your fueling systems needs.

Whether fueling heavy equipment, over-the-road tractor trailers, lawnmowers, or golf carts, Modern Welding Company has the fuel dispensing system for your application. For over seventy years, Modern Welding Company has been the industry leader in manufacturing UL Listed underground and aboveground storage tanks. Modern Welding Company has nine manufacturing subsidiaries located coast to coast, offering regional service at competitive prices. Visit our website at www.modweldco.com for a complete list of our products and facilities. You can even "Request a Quote" online.

Modern's Aboveground Systems Technology (AST) consists of any of the following UL Listed aboveground storage tanks:

Single Wall Construction

- ✓ UL-142 Horizontal Tank
- ✓ Vertical Configurations
- ✓ Rectangular Configurations

Double Wall Construction

- ✓ UL-142 Horizontal Tank
- ✓ Vertical Configurations
- ✓ Rectangular Configurations
- ✓ STI's F-921/Flameshield Configurations
- ✓ Fireguard®, 2 Hour "Fire Rated" Configuration
- ✓ Modern "IOC", Integrated Overflow Protection Tank
- ✓ SuperVault™ MH, 4 Hour "Fire Rated", Multi Hazard Tank

The Professionals...
Modern Welding Company
The Smart Fueling Choice.



Dispensing Diesel Fuel With 20,000 Gallon Fireguard Tank



Industrial Applications

Terminal Fueling



Fuel Dispensing Configurations to meet Your Requirements



Agricultural Applications



Ethanol Fuels

The Steel Tank Institute has researched compatibility issues concerning the storage of ethanol based fuels. Shop fabricated "Steel" underground and aboveground storage tanks, when used for the storage of ethanol based fuels, has exhibited no long term detrimental structural or permeation issues. As with all fuels, STI recommends that tank owners implement a maintenance program for all tanks and associated equipment, including monitoring and removing water that may accumulate within the tank system.

Modern's ASTs offer the components.

- ✓ Listed tank
- ✓ Manway (as required)
- ✓ Normal vent
- ✓ Emergency vents
- ✓ Spill container
- ✓ Locking fill cap
- ✓ Fill pipe adapter
- ✓ Level gauge
- ✓ Interstitial leak detector†
- ✓ Drop tube
- ✓ Overfill valve
- ✓ Overfill alarm
- ✓ Block valve
- ✓ Anti-siphon valve
- ✓ Pressure relief
- ✓ Piping & fittings
- ✓ Dispensers
- ✓ Breakaway
- ✓ Automatic nozzles
- ✓ Hose
- ✓ Dispenser mount
- ✓ Impact valve
- ✓ Decals
- ✓ O&M manual
- ✓ Pumps

Plus a wide variety of options to meet your specific needs.

- ✓ Stairs
- ✓ Filters
- ✓ Stage I or II accessories
- ✓ Swivel
- ✓ Card reader
- ✓ Rain Shields
- ✓ Plus many more

† Only applicable on doublewall tanks.

Modern's AST 40

With a fueling rate of up to 40 GPM*, Modern's AST-40 provides convenience for large fleets, marinas, fueling of heavy equipment, and even retail sales where allowed by local authorities. Modern's AST 40 is the answer for almost any high volume fuel application.

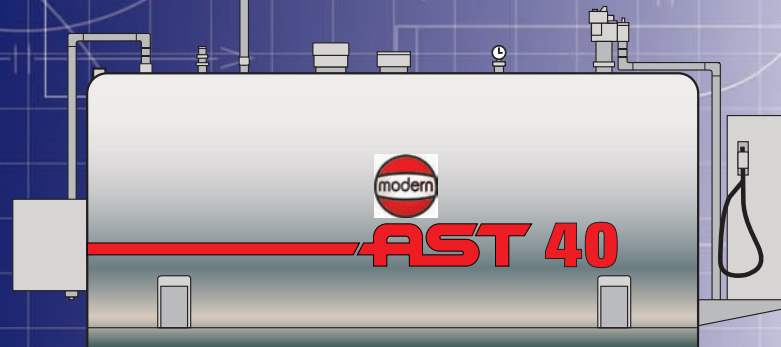

Modern's AST 20

Modern's AST 20 offers fueling at a rate up to 20 GPM* for small fleets, municipal garages, school bus facilities, motor sport venues, etc.



Modern's AST 10

Modern's AST 10 small units are designed to deliver up to 10 GPM*. The AST 10 is ideal for golf courses, fork lift fueling and other lower volume yard applications. This basic package represents the most economical way to do your fueling.

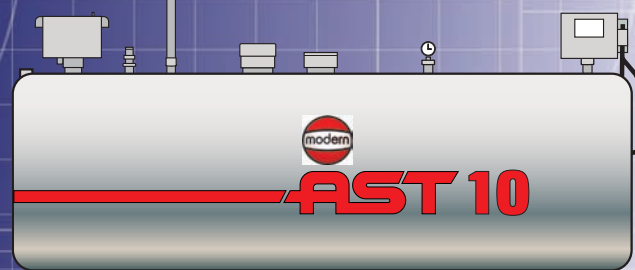

* Gallons per minute ratings based on gasoline service



MODERN WELDING CO., INC.

Corporate Offices

2880 New Hartford Road • Owensboro, KY 42303 • Phone: 270-685-4400 • Fax: 270-684-6972

1 800 922 1932

www.modweldco.com • E-mail: modern@modweldco.com

Manufacturing Subsidiaries

Modern Welding Co. of Owensboro, Inc.

1450 E. Parrish Ave.
Owensboro, Kentucky 42303
Phone: 270-683-5323
Fax: 270-684-5245
modern1@modweldco.com

Modern Welding Co. of Ohio, Inc.

One Modern Way
Newark, Ohio 43055
Phone: 740-344-9425
Fax: 740-344-6018
modern5@modweldco.com

Modern Welding Co. of Florida, Inc.

1801 Atlanta Ave.
Orlando, Florida 32806
Phone: 407-843-1270
Fax: 407-423-8187
modern6@modweldco.com

Modern Welding Co. of Texas, Inc.

2 Locations
715 Sakowitz St.
Houston, Texas 77020
Phone: 713-675-4211
Fax: 713-673-4062
modern7@modweldco.com

200 N. Main St.
Rhame, Texas 76078
Phone: 817-636-2215
Fax: 817-636-2680
modern15@modweldco.com

Modern Welding Co. of Iowa, Inc.

2818 Mt. Pleasant Rd.
Burlington, Iowa 52601
Phone: 319-754-6577
Fax: 319-754-8428
modern8@modweldco.com

Modern Welding Co. of California, Inc.

4141 N. Brawley Ave.
Fresno, California 93722
Phone: 559-275-9353
Fax: 559-275-4381
modern10@modweldco.com

Modern Welding Co. of Georgia, Inc.

300 Prep Phillips Dr.
Augusta, Georgia 30901
Phone: 706-722-3411
Fax: 706-724-8133
modern14@modweldco.com

Modern Custom Fabrication, Inc.

2421 E. California Ave.
Fresno, California 93271
Phone: 559-264-4741
Fax: 559-237-3413
modern16@modweldco.com